

# Our Dynamic Universe



## Homework Questions Part 2

Cover image: Hubble Space Telescope, NASA



## Contents

<b>Section 4: Gravitation</b>	1
<b>Section 5: Special Relativity</b>	8
<b>Section 6: The Expanding Universe</b>	9
<b>Section 7: Big Bang Theory</b>	13
<b>Section 8: Uncertainties in Mechanics</b>	15
<b>Section 9: Open-ended Questions</b>	21

**DATA SHEET**  
COMMON PHYSICAL QUANTITIES

Quantity	Symbol	Value	Quantity	Symbol	Value
Speed of light in vacuum	$c$	$3.00 \times 10^8 \text{ m s}^{-1}$	Planck's constant	$h$	$6.63 \times 10^{-34} \text{ J s}$
Magnitude of the charge on an electron	$e$	$1.60 \times 10^{-19} \text{ C}$	Mass of electron	$m_e$	$9.11 \times 10^{-31} \text{ kg}$
Universal Constant of Gravitation	$G$	$6.67 \times 10^{-11} \text{ m}^3 \text{ kg}^{-1} \text{ s}^{-2}$	Mass of neutron	$m_n$	$1.675 \times 10^{-27} \text{ kg}$
Gravitational acceleration on Earth	$g$	$9.8 \text{ m s}^{-2}$	Mass of proton	$m_p$	$1.673 \times 10^{-27} \text{ kg}$
Hubble's constant	$H_0$	$2.3 \times 10^{-18} \text{ s}^{-1}$			

**REFRACTIVE INDICES**

The refractive indices refer to sodium light of wavelength 589 nm and to substances at a temperature of 273 K.

Substance	Refractive index	Substance	Refractive index
Diamond	2.42	Water	1.33
Crown glass	1.50	Air	1.00

**SPECTRAL LINES**

Element	Wavelength/nm	Colour	Element	Wavelength/nm	Colour
Hydrogen	656	Red	Cadmium	644	Red
	486	Blue-green		509	Green
	434	Blue-violet		480	Blue
	410	Violet	<i>Lasers</i>		
	397	Ultraviolet	<i>Element</i>	<i>Wavelength/nm</i>	<i>Colour</i>
	389	Ultraviolet	Carbon dioxide	9550 } 10590 }	Infrared
Sodium	589	Yellow	Helium-neon	633	Red

**PROPERTIES OF SELECTED MATERIALS**

Substance	Density/kg m <sup>-3</sup>	Melting Point/K	Boiling Point/K
Aluminium	$2.70 \times 10^3$	933	2623
Copper	$8.96 \times 10^3$	1357	2853
Ice	$9.20 \times 10^2$	273	....
Sea Water	$1.02 \times 10^3$	264	377
Water	$1.00 \times 10^3$	273	373
Air	1.29	....	....
Hydrogen	$9.0 \times 10^{-2}$	14	20

The gas densities refer to a temperature of 273 K and a pressure of  $1.01 \times 10^5 \text{ Pa}$ .

## Gravitation

1. At a funfair, a prize is awarded if a coin is tossed into a small dish. The dish is mounted on a shelf above the ground as shown.

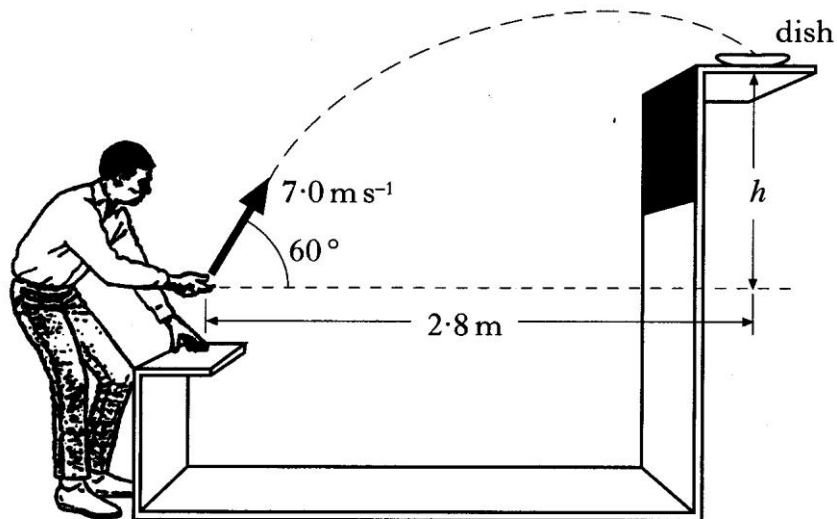

A contestant projects the coin with a speed of  $7.0 \text{ m s}^{-1}$  at an angle of  $60^\circ$  to the horizontal. When the coin leaves his hand, the **horizontal distance** between the coin and the dish is  $2.8 \text{ m}$ . The coin lands in the dish.

The effect of air resistance on the coin may be neglected.

(a) Calculate:

- (i) the horizontal component of the initial velocity of the coin; 1
- (ii) the vertical component of the initial velocity of the coin. 1

(b) Show that the time taken for the coin to reach the dish is  $0.8 \text{ s}$ . 1

(c) What is the height,  $h$ , of the shelf above the point where the coin leaves the contestant's hand? 2

(d) How does the value of the kinetic energy of the coin when it enters the dish compare with the kinetic energy of the coin just as it leaves the contestant's hand? Justify your answer. 2

(7)

2. A golfer on an elevated tee hits a golf ball with an initial velocity of  $35.0 \text{ m s}^{-1}$  at an angle of  $40^\circ$  to the horizontal.

The ball travels through the air and hits the ground at point R.

Point R is 12 m below the height of the tee, as shown.

**diagram not to scale**

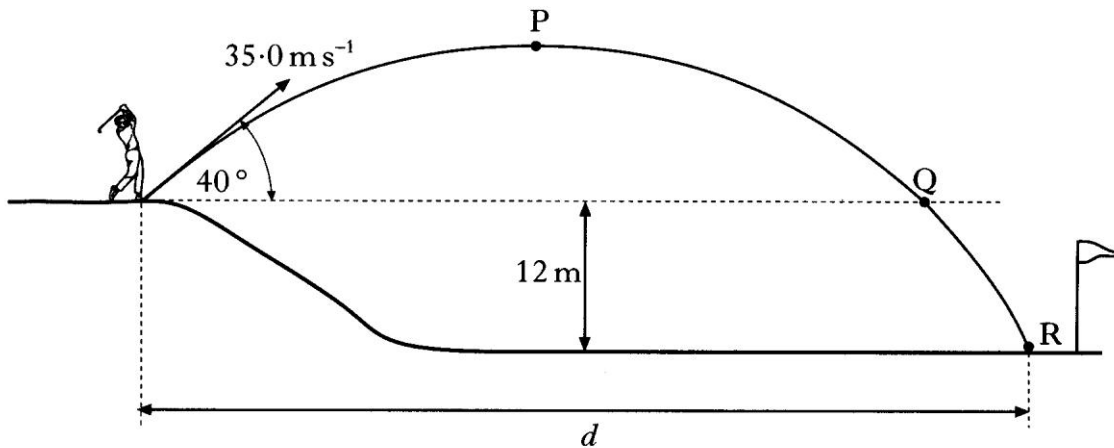

The effects of air resistance can be ignored.

(a) Calculate:

- (i) the horizontal component of the initial velocity of the ball; 1
- (ii) the vertical component of the initial velocity of the ball; 1
- (iii) the time taken for the ball to reach its maximum height at point P. 2

(b) From its maximum height at point P, the ball falls to point Q, which is at the same height as the tee.

It then takes a further 0.48 s to travel from Q until it hits the ground at R.

Calculate the total horizontal distance  $d$  travelled by the ball 3

(7)

3. A basketball player throws a ball with an initial velocity of  $6.5 \text{ m s}^{-1}$  at an angle of  $50^\circ$  to the horizontal. The ball is  $2.3 \text{ m}$  above the ground when released

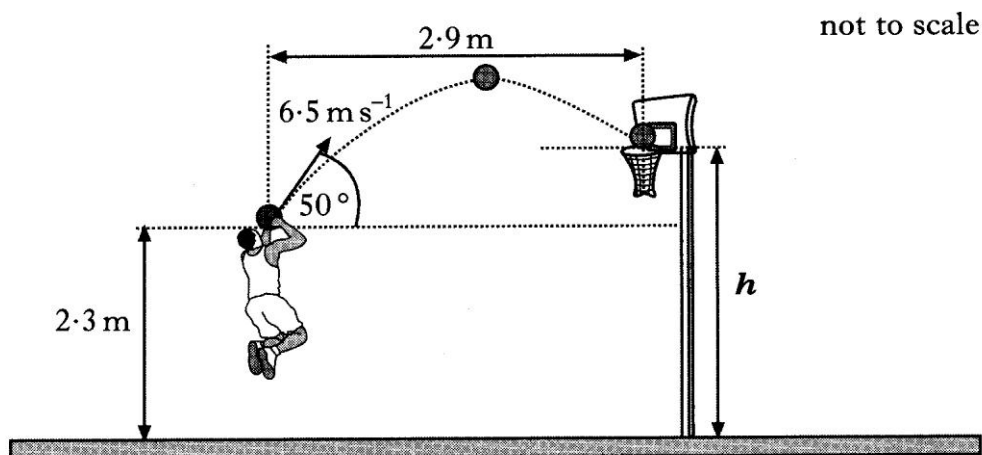

The ball travels a horizontal distance of  $2.9 \text{ m}$  to reach the top of the basket.

The effects of air resistance can be ignored.

(a) Calculate:

- (i) the horizontal component of the initial velocity of the ball; 1
- (ii) the vertical component of the initial velocity of the ball. 1

(b) Show that the time taken for the ball to reach the basket is  $0.69 \text{ s}$ . 1

(c) Calculate the height  $h$  of the top of the basket. 2

(d) A student observing the player makes the following statement.

*“The player should throw the ball with a higher speed at the same angle. The ball would then land in the basket as before but it would take a shorter time to travel the  $2.9 \text{ m}$ .”*

**Explain** why the student’s statement is incorrect. 2

(7)

4. A ball is rolled up a slope so that it is travelling at  $14 \text{ m s}^{-1}$  as it leaves the end of the slope.

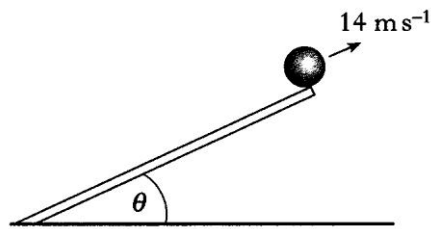

- (a) The slope is set so that the angle to the horizontal,  $\theta$ , is  $30^\circ$ .

Calculate the vertical component of the velocity of the ball as it leaves the slope.

1

- (b) The slope is now tilted so that the angle to the horizontal,  $\theta$ , is increased. The ball is rolled so that it still leaves the end of the slope at  $14 \text{ m s}^{-1}$ .

Describe and explain what happens to the maximum height reached by the ball.

2

(3)

5. An archer fires an arrow at a target which is 30 m away.

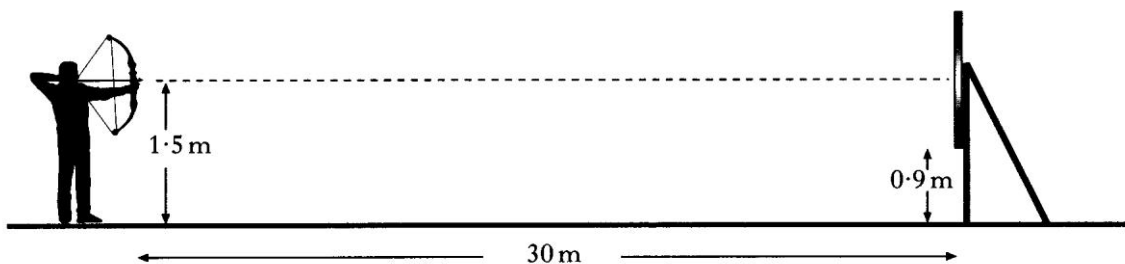

The arrow is fired horizontally from a height of 1.5 m and leaves the bow with a velocity of  $100 \text{ m s}^{-1}$ .

The bottom of the target is 0.90 m above the ground.

Show by calculation that the arrow hits the target.

3

(3)



6. The fairway on a golf course is in two horizontal parts separated by a steep bank as shown below.

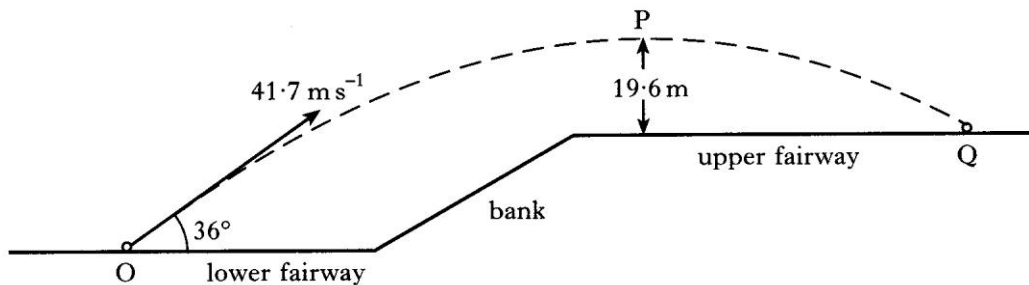

A golf ball at point O is given an initial velocity of  $41.7 \text{ m s}^{-1}$  at  $36^\circ$  to the horizontal.

The ball reaches a maximum vertical height at point P above the upper fairway. Point P is  $19.6 \text{ m}$  above the upper fairway as shown. The ball hits the ground at point Q.

The effect of air resistance on the ball may be neglected.

(a) Calculate:

- (i) the horizontal component of the initial velocity of the ball; 1
- (ii) the vertical component of the initial velocity of the ball. 1

(b) Show that the time taken for the ball to travel from point O to point Q is  $4.5 \text{ s}$ . 3

(c) Calculate the horizontal distance travelled by the ball. 2

(7)

7. (a) A long jumper devises a method for estimating the horizontal component of his velocity during a jump.

His method involves first finding out how high he can jump **vertically**.

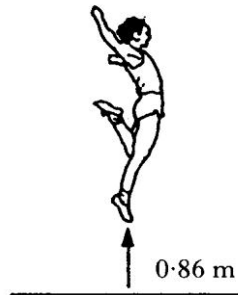

He finds that the maximum height he can jump is 0.86 m.

- (i) Show that his initial vertical velocity is  $4.1 \text{ m s}^{-1}$ . 2
- (ii) He now assumes that when he is long jumping, the initial vertical component of his velocity at take-off is  $4.1 \text{ m s}^{-1}$ .

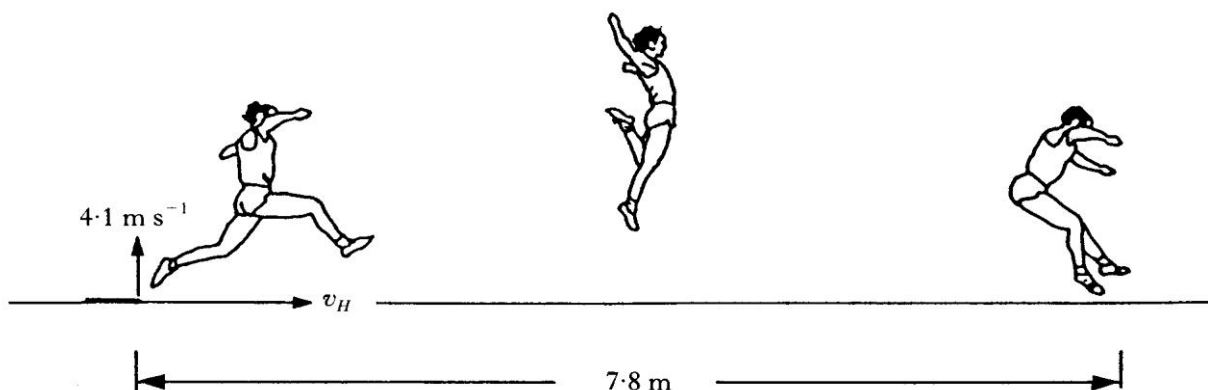

The length of his long jump is 7.8 m.

Calculate the value that he should obtain for the horizontal component of his velocity,  $v_H$ . 3

- (b) His coach tells him that, during his 7.8 m jump, his maximum height above the ground was less than 0.86 m. Ignoring air resistance, state whether his actual horizontal component of velocity was greater or less than the value calculated in part (a) (ii). You must justify your answer. 2
- (7)

8. A satellite orbits 400 km above the surface of the Earth as shown.

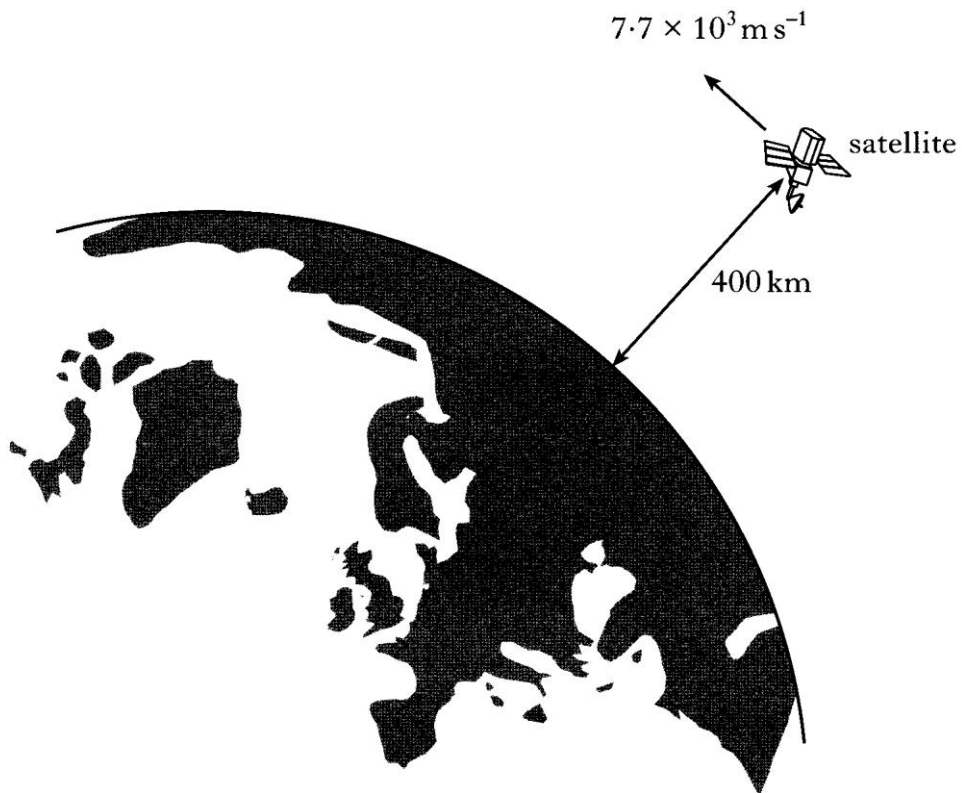

The Earth has a mass of  $6.0 \times 10^{24}$  kg and a radius of  $6.4 \times 10^6$  m.

The satellite has a mass of 900 kg and a speed of  $7.7 \times 10^3$  m s<sup>-1</sup>.

- (a) Explain why the satellite remains in orbit around the Earth. 2
- (b) Calculate the gravitational force acting on the satellite. 2
- (4)

9. (a) (i) State what is meant by the term *gravitational field strength*. 1

(ii) The gravitational field strength  $g$  at the surface of Mars is  $3.7 \text{ N kg}^{-1}$ .

The radius  $r$  of Mars is  $3.4 \times 10^3 \text{ km}$ .

(A) Use Newton's universal law of gravitation to show that the mass of Mars is given by the equation

$$M = \frac{gr^2}{G}$$

where  $G = 6.67 \times 10^{-11} \text{ m}^3 \text{ kg}^{-1} \text{ s}^{-2}$ . 2

(B) Calculate the mass of Mars. 1

(b) A spacecraft of mass  $100 \text{ kg}$  is in a circular orbit  $300 \text{ km}$  above the surface of Mars.

Calculate the force exerted by Mars on the satellite. 2

(6)

## Special Relativity

1. A beam of charged particles is accelerated in particle accelerators to a speed of  $2.0 \times 10^8 \text{ m s}^{-1}$ .

(a) The particles are unstable and decay with a half-life of  $8.2 \times 10^{-7} \text{ s}$  when at rest.

Calculate the half-life of the particles in the beam as observed by a stationary observer.

2

(b) Calculate the mean distance travelled by a particle in the beam before it decays as observed by a stationary observer.

2

(4)

## The Expanding Universe

1. (a) A car approaches a building where there is a stationary observer. The car sounds its horn

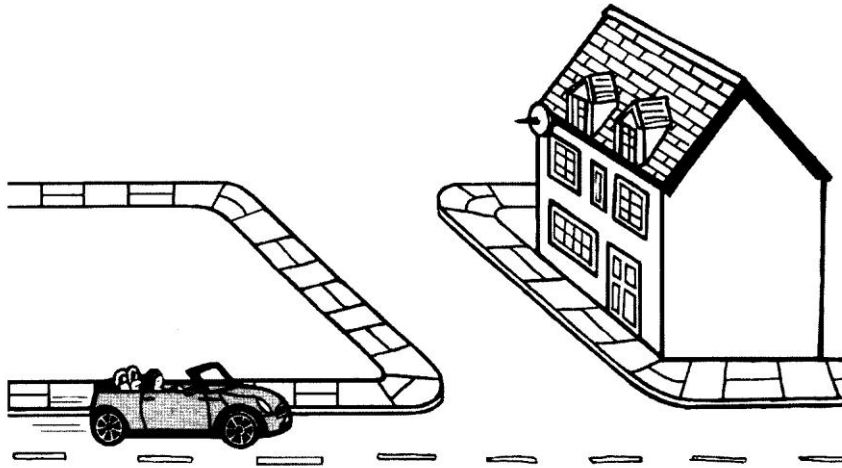

The speed of the car is  $25.0 \text{ m s}^{-1}$  and the frequency of the sound emitted by the horn is  $1250 \text{ Hz}$ .

- (i) Explain in terms of wavefronts why the sound heard by the observer does not have a frequency of  $1250 \text{ Hz}$ . You may wish to include a diagram to support your answer. 2
- (ii) Calculate the frequency of the sound from the horn heard by the observer. 2

- (b) The spectrum of light from most stars contains lines corresponding to helium gas.

The diagram below shows the helium spectrum from the Sun.

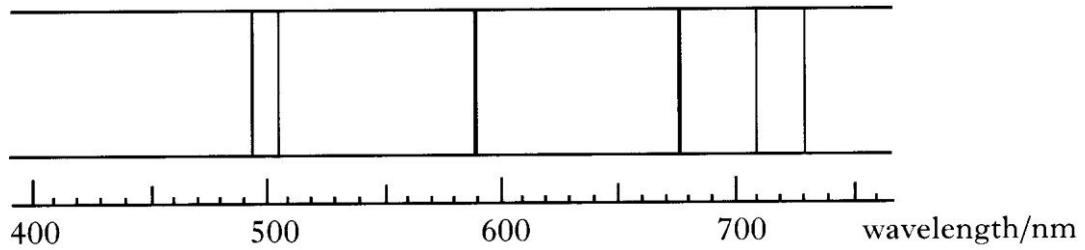

The diagram below shows the helium spectrum from a distant star.

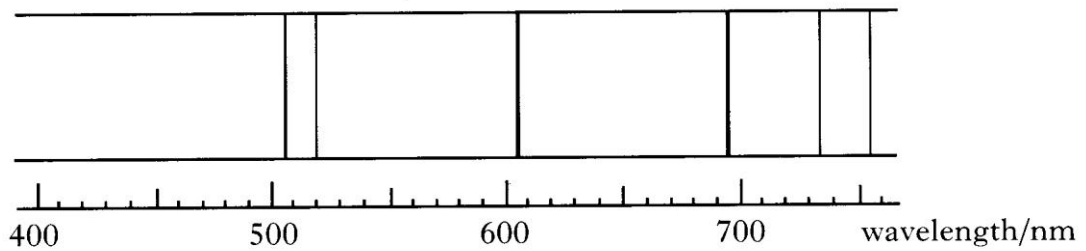

By comparing these spectra, what conclusion can be made about the distant star? Justify your answer.

2

(6)

2. A train emits a sound of frequency 800 Hz as it passes through a station. The sound is heard by a person on the station platform as shown.

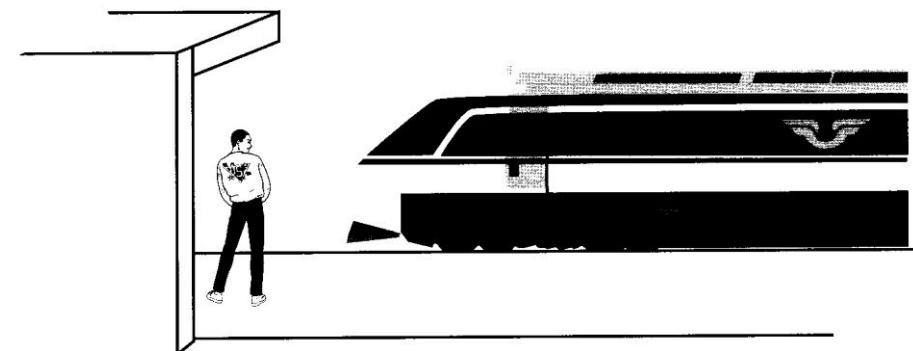

- (a) Describe how the frequency of the sound, heard by the person, changes as the train passes through the station. 1
- (b) Explain, in terms of wavefronts, why this frequency change occurs. You may wish to include a diagram as part of your answer. 2
- (c) At one instant the person hears a sound of frequency 760 Hz.

Calculate the speed of the train relative to the person on the platform at this time. 2

(5)

3. (a) A car horn produces a note of frequency 300 Hz.

The horn is sounded as the car is moving at  $30 \text{ m s}^{-1}$  away from a stationary observer.

Calculate the frequency heard by the observer. 2

- (b) An observer on Earth notes that the frequency of light from a distant galaxy is Doppler shifted towards the red end of the spectrum.

Describe how the galaxy is moving relative to the Earth. You must justify your answer. 2

(4)



4. By observing the spectrum of light received from galaxy M101, astronomers have determined that the galaxy is moving away from us with a velocity of  $5.5 \times 10^5 \text{ m s}^{-1}$ .
- (a) Calculate the distance of the galaxy from us. 3
- (b) The observation that galaxies are moving away from us is evidence for the expanding universe. As the universe expands it cools down.
- What property of the Cosmic Microwave Background has been measured by astronomers to determine the present temperature of the universe? 1
- (4)
5. (a) Explain what is meant by red shift and why it provides evidence for the Big Bang Theory, 2
- (b) (i) Explain what is meant by the term *dark matter*. 1
- (iii) Explain why the study of dark matter is important to the understanding of the fate of the Universe. 2
- (5)

6. (a) In 1929 Edwin Hubble suggested that distant galaxies are moving away (receding) from our own galaxy with velocities that are directly proportional to the distance to the galaxy. This is known as Hubble's Law.

Some data collected by Hubble are given in the table below.

galaxy	distance to galaxy /light years	velocity of recession /m s <sup>-1</sup>
NGC 221	$9.0 \times 10^5$	$2.0 \times 10^5$
NGC 379	$2.3 \times 10^7$	$2.2 \times 10^6$
Gemini cluster	$1.4 \times 10^8$	$2.3 \times 10^7$

- (i) Using **all** of the data, determine whether or not this data supports Hubble's Law. 3
- (ii) Use the data on the Gemini cluster given in the table to calculate a value for the Hubble constant,  $H_0$ . 3
- (iii) Comment on how this early value for the Hubble constant compares to the accepted value today. 1
- (b) The speed of recession of the galaxies is found from observations of redshift.
- (i) State what is meant by the term *redshift*. 1
- (ii) Explain why the expansion of space will cause light from more distant galaxies to show a greater redshift. 2
- (10)

## Big Bang Theory

1. Mu Cephei is possibly the largest star yet discovered. Its radius is  $1.2 \times 10^{12}$  m and its surface temperature is 3500 K.

(a) Calculate the wavelength of the peak in the black body radiation curve for Mu Cephei.

2

(b) Copy the graph axes below and sketch the black body radiation curve for Mu Cephei.



2

(4)

2. All stars emit radiation with a range of wavelengths. The peak wavelength of radiation,  $\lambda_{\text{peak}}$ , emitted from a star is related to the surface temperature, T, of the star.

The table gives the surface temperatures, in kelvin, of four different stars and the peak wavelength radiated from each star.

Surface temperature of star T/K	Peak wavelength radiated $\lambda_{\text{peak}}$ /m
4200	$6.90 \times 10^{-7}$
5800	$5.00 \times 10^{-7}$
7900	$3.65 \times 10^{-7}$
12 000	$2.42 \times 10^{-7}$

- (a) Use **all** the data in the table to show that the relationship between the surface temperature, T, of a star and the peak wavelength radiated,  $\lambda_{\text{peak}}$ , from the star is

$$T = \frac{2.9 \times 10^{-3}}{\lambda_{\text{peak}}} \quad 2$$

- (b) The blue supergiant star Eta Carinae is one of the largest and most luminous stars in our galaxy. It emits radiation with a peak wavelength of 76 nm.

Calculate the surface temperature, in kelvin, of this star. 2

- (c) Radiation of peak wavelength 1.06 mm can be detected on Earth coming from all directions in space.

(i) What name is given to this radiation? 1

(ii) Give a reason why the existence of this radiation supports the Big Bang Theory. 1

(6)

## Uncertainties in Mechanics

1. A student uses the apparatus shown to measure the average acceleration of a trolley travelling down a track.

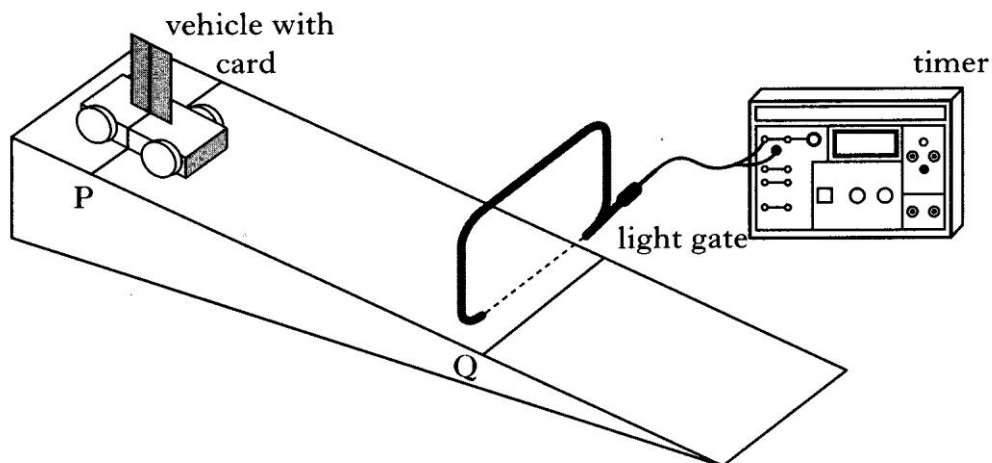

The line on the trolley is aligned with line P on the track.

The trolley is released from rest and allowed to run down the track.

The timer measures the time for the card to pass through the light gate.

The procedure is repeated a number of times and the results shown below.

0.015 s   0.013 s   0.014 s   0.019 s   0.017 s   0.018 s

(a) Calculate:

- (i) the mean time for the card to pass through the light gate; 1
- (ii) the approximate absolute random uncertainty in this value. 1

(b) The length of the card is 0.020 m and the distance PQ is 0.60 m.

Calculate the acceleration of the trolley (an uncertainty in this value is not required). 3

(5)

2. The manufacturers of tennis balls require that the balls meet a given standard.

When dropped from a certain height onto a test surface, the balls must rebound to within a limited range of heights.

The ideal ball is one which, when dropped from rest from a height of 3.15 m, rebounds to a height of 1.75 m as shown below.

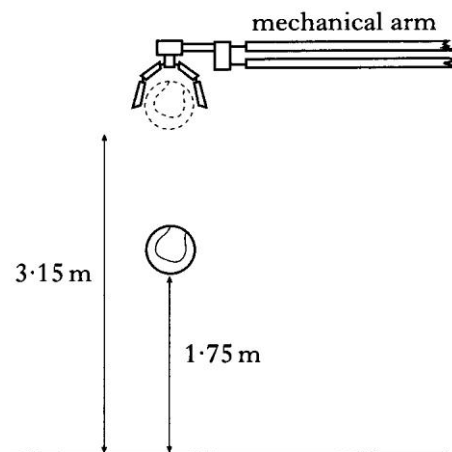

(a) Assuming air resistance is negligible, calculate:

- (i) the speed of an ideal ball just before contact with the ground; 2
- (ii) the speed of this ball just after contact with the ground. 1

(b) When a ball is tested six times, the rebound heights are measured to be

1.71 m    1.78 m    1.72 m    1.76 m    1.73 m    1.74 m

Calculate:

- (i) the mean value of the height of the bounce; 1
  - (ii) the approximate absolute random uncertainty in this value. 1
- (5)

3. Golf clubs are tested to ensure they meet certain standards.

(a) In one test, a securely held clubhead is hit by a small steel pendulum. The time of contact between the clubhead and the pendulum is recorded.

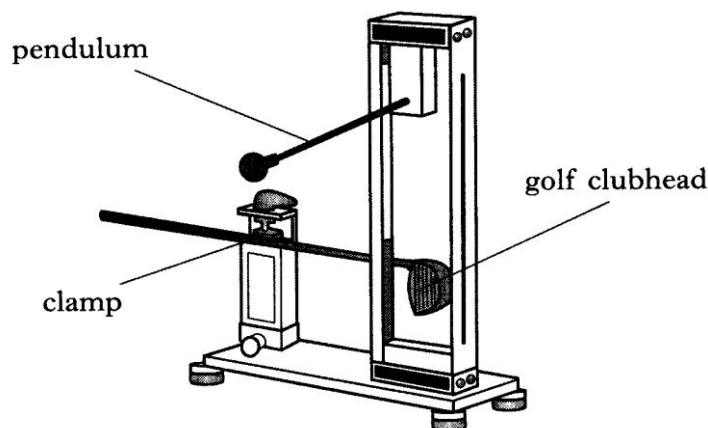

The experiment is repeated several times.

The results are shown.

248  $\mu\text{s}$       259  $\mu\text{s}$       251  $\mu\text{s}$       263  $\mu\text{s}$       254  $\mu\text{s}$

(i) Calculate:

(A) the mean contact time between the clubhead and the pendulum; 1

(B) the approximate absolute random uncertainty in this value. 1

(ii) In this test, the standard required is that the maximum value of the mean contact time must not be greater than 257  $\mu\text{s}$ .

Does the club meet this standard? You must justify your answer. 1

(b) In another test, a machine uses a club to hit a stationary golf ball.

The mass of the ball is  $4.5 \times 10^{-2}$  kg. The ball leaves the club with a speed of  $50.0 \text{ m s}^{-1}$ . the time of contact between the club and the ball is 450  $\mu\text{s}$ .

(i) Calculate the average force exerted on the ball by the club. 2

(ii) The test is repeated using a different club and an identical ball/ The machine applies the same average force on the ball but with a longer contact time.

What effect, if any does this have on the speed of the ball as it leaves the club? Justify your answer. 2

(7)

4. A basketball is held below a motion sensor. The basketball is released from rest and falls onto a wooden block. The motion sensor is connected to a computer so that graphs of the motion of the basketball can be displayed.

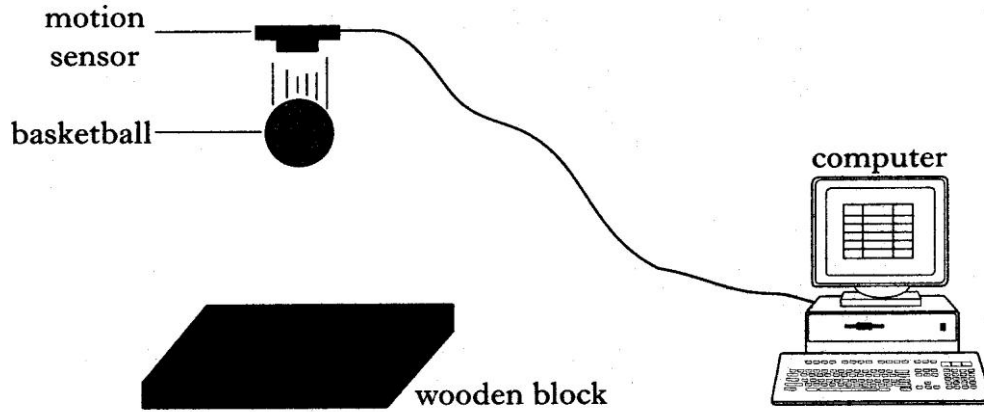

A displacement-time graph for the motion of the basketball from the instant of its release is shown.

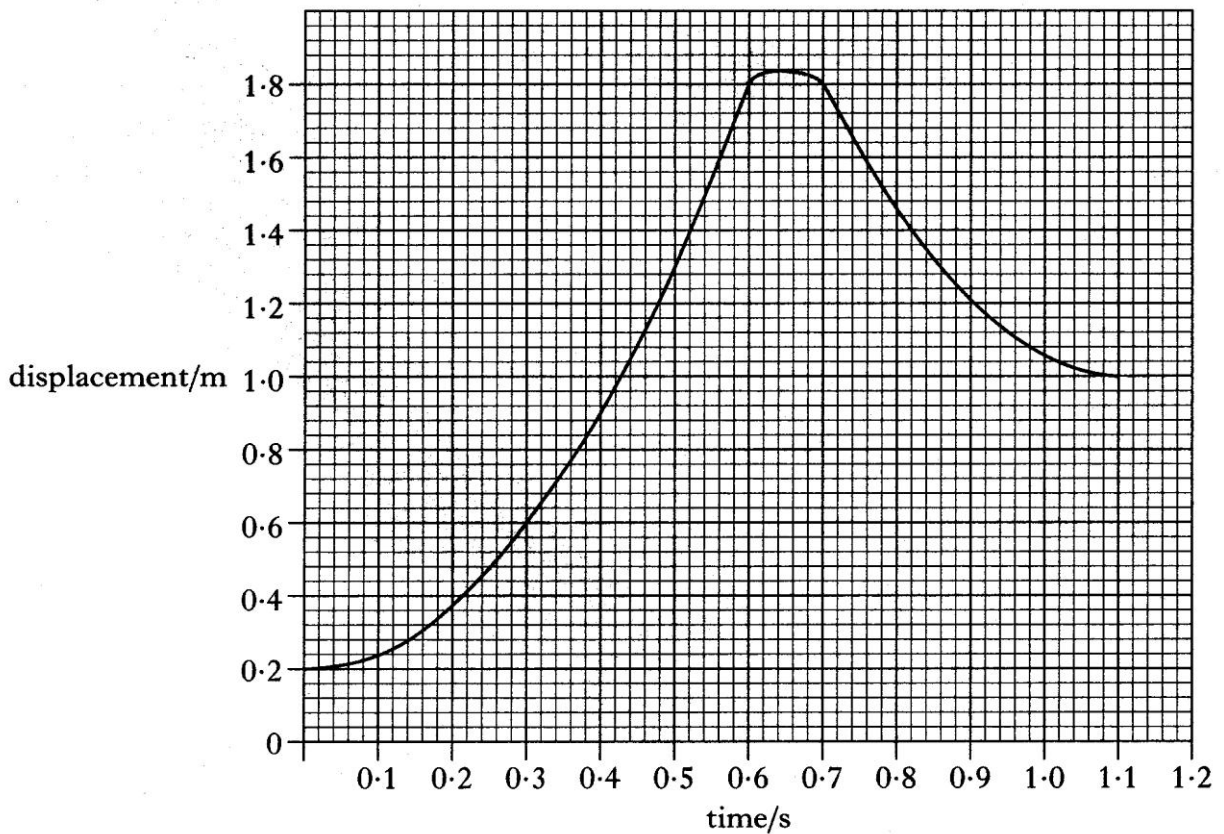



- (a) (i) What is the distance between the motion sensor and the top of the basketball when it is released? 1
- (ii) How far does the basketball fall before it hits the wooden block? 1
- (iii) Show, by calculation, that the acceleration of the basketball as it falls is  $8.9 \text{ m s}^{-2}$ . 1

- (b) The basketball is now dropped several times from the same height. The following values are obtained for the acceleration of the basketball.

$8.9 \text{ m s}^{-2}$      $9.1 \text{ m s}^{-2}$      $8.4 \text{ m s}^{-2}$      $8.5 \text{ m s}^{-2}$      $9.0 \text{ m s}^{-2}$

Calculate:

- (i) the mean of these values; 1
- (ii) the approximate random uncertainty in the mean. 1
- (c) The wooden block is replaced by a block of sponge of the same dimensions. The experiment is repeated and a new graph obtained.

Describe and explain any **two** differences between this graph and the original graph. 2

(7)

5. The apparatus in the diagram is being used to investigate the average force exerted by a golf club on a golf ball.

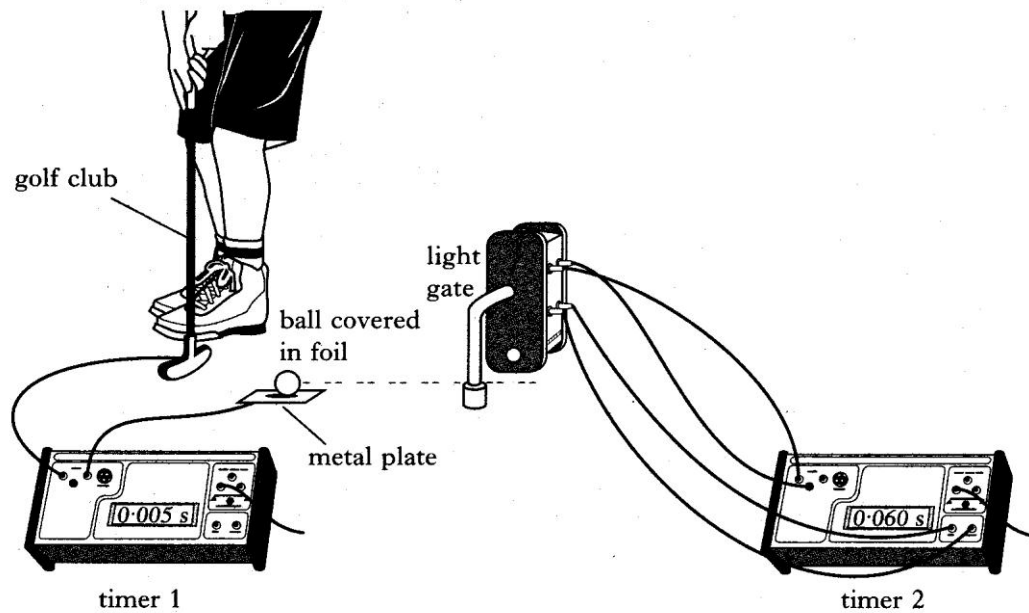

The club hits the stationary ball. Timer 1 records the time of contact between the club and the ball. Timer 2 records the time taken for the ball to pass through the light gate beam.

The mass of the ball is  $45.00 \pm 0.01$  g.

The time of the contact between club and ball is  $0.005 \pm 0.001$  s.

The time for the ball to pass through the light gate beam is  $0.060 \pm 0.001$  s.

The diameter of the ball is  $24 \pm 1$  mm.

- (a) (i) Calculate the speed of the ball as it passes through the light gate. 2
- (ii) Calculate the average force exerted on the ball by the golf club. 2
- (b) (i) Show by calculation which measurement contributes the largest percentage uncertainty in the final value of the average force on the ball. 2
- (ii) Express your numerical answer to (a) (ii) in the form  
 final value  $\pm$  absolute uncertainty 1

(7)

## Open-ended Questions

1. In a book in which he describes his childhood experiences, an author describes how he used to drop peanuts down the stairwell of a department store. This would annoy the shop owner '*who would come flying up the stairs at about the speed that the peanut had gone down, giving you less than five seconds to scramble away to freedom*'.

Using physics principles, comment on the way the author has compared the speed of the peanut and the shop owner.

3

2. A trolley is at rest on a slope. It is pushed then released. The velocity–time graph shows the resultant motion of the trolley.

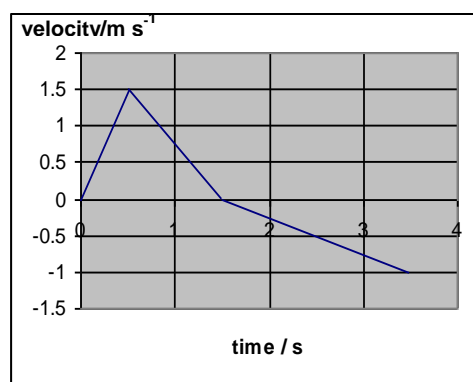

Use your knowledge of physics to comment on the shape of the graph.

3

3. A student holds a ball at rest then allows it to fall. The ball accelerates freely to the ground.

The student notes that before release the momentum of the ball is zero but after release it has a momentum.

The student concludes that this shows that the law of conservation of momentum is not always obeyed.

Use your knowledge of physics to show that the student's statement is untrue.

3

4. A rubber ball X and a ball Y with a very sticky surface have the **same mass**. They are thrown, with the **same speed**, at a wall.

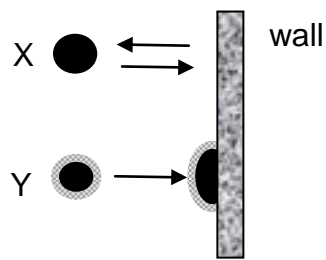

The ball X rebounds back along its original path. Ball Y sticks to the wall.

A student states 'Ball X will always exert a greater force on the wall than that exerted by Y.'

Use your knowledge of physics to comment on this statement.

3

5. A rubber ball X and a ball Y with a very sticky surface have the **same mass**. They are thrown, with the **same speed**, at a wall.

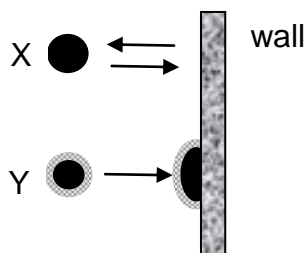

The ball X rebounds back along its original path. Ball Y sticks to the wall.

A student states 'The change in momentum of ball X is greater than the change in momentum of ball Y. This means that ball X will always exert a greater force on the wall than that exerted by Y on the wall.'

Use your knowledge of physics to comment on this statement.

3

6. A ball is thrown vertically into the air.

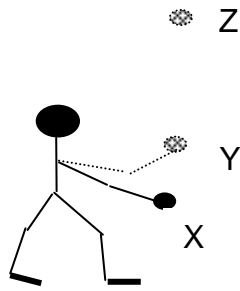

The ball starts from rest at point X.

It leaves the thrower's hand at point Y and travels vertically upwards to point Z.

A student states that 'the magnitude of the acceleration of the ball is *always* greater when *being* accelerated from rest (between X and Y) than when it is in the air from Y to Z.'

Use your knowledge of physics to comment on this statement.

3

7. A comedian remarks that '*When you fall it is not the falling which hurts but the coming to rest.*'

Use your knowledge of physics to comment on this remark.

3

8. When you jump from a height of 5 m into water it usually does not cause any damage. Jumping from the same height onto a concrete surface usually causes injury.

Use physics principles to comment on these statements.

3

9. A student states '*When a **single** force acts on an object the object can never remain stationary or move with constant speed.*'

Use physics principles to comment this statement.

3

10. A ball is thrown horizontally from a cliff.

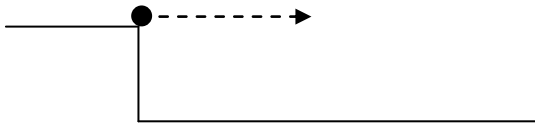

A student states 'The acceleration of the ball can never be parallel to the velocity of the ball.'

Use your knowledge of physics to comment on the truth or otherwise of this statement.

3

11. A ball can be thrown into the air at an angle of  $45^\circ$  to the horizontal.

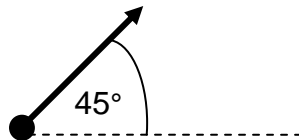

A student states that 'The acceleration of the ball can never be perpendicular to the velocity of the ball.'

Use your knowledge of physics to comment on the truth or otherwise of this statement.

3

12. A trolley is at rest on a slope. It is pushed up the slope then released, as shown in the diagram.

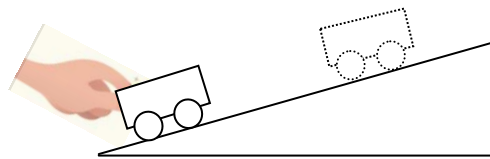

Use your knowledge of physics to describe and explain the resultant motion of the trolley.

3

13. A student observes a gardener pushing a wheelbarrow.

The student knows that the gardener exerts a force on the wheelbarrow and that the wheelbarrow exerts a force of equal size in the opposite direction on the gardener.

The student has difficulty explaining why the wheelbarrow moves forward.



Using physics principles give your explanation for the movement of the wheelbarrow.

3

14. A student sees a diagram of a force acting on a combination of blocks as shown.

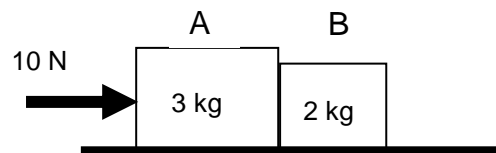

The student reasons that block A exerts a force on block B and block B exerts an equal force in the opposite direction on block A. The student then cannot understand why the blocks move.

Use your knowledge of physics to give an explanation for the movement of the blocks.

3

15. A commentator at a skateboarding competition describes the movement of a competitor on a ramp as shown in the diagram.

*'The skateboarder has gained enough force on the downslope to let her reach the very top of the upslope.'*

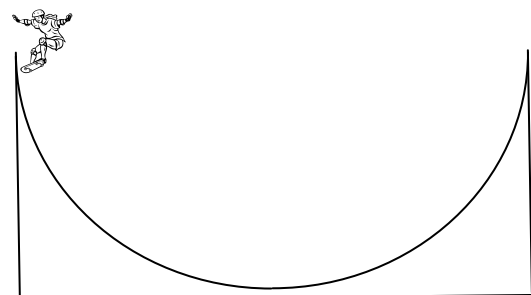

Using physics principles, comment on the way the commentator has described the movement of this competitor.

3

16. A book has a drawing of an 'invention' that will provide a means of transport.

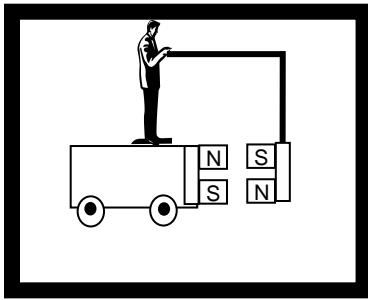

A magnet is attached to a trolley and a person on the trolley holds a second magnet in front of the first magnet.

The North Pole N of a magnet is known to attract the South Pole S of a magnet.

Using physics principles explain why this invention cannot work.

3

17. A box is pulled along a floor by a force of 200 N as shown in the diagram.

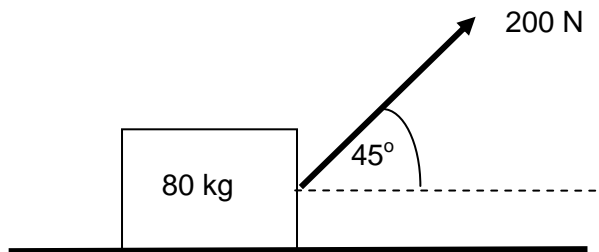

Use your knowledge of physics to comment on why this is not the most efficient way to move the box.

3

18. A student is watching the launch of a rocket.

The student states that the rocket takes off because the gas from the rocket engine pushes on the ground.

Using physics principles show that the student's statement is untrue.

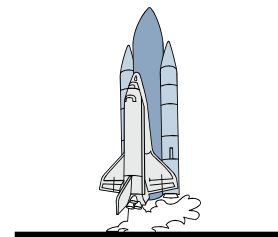

3

19. A television commentator was heard to describe a free kick in a football match in the following way.

*'It was a magnificent free kick. The ball flew into the net. Once it left his foot it really accelerated into the goal.'*

Using physics principles, comment on the way the television commentator has described the motion of the ball.

3



20. On 1 April, a car manufacturer placed an advertisement for a new system that could be fitted to cars and was called 'Magnetic Tow Technology'. It was of course an April Fool – the system does not exist.

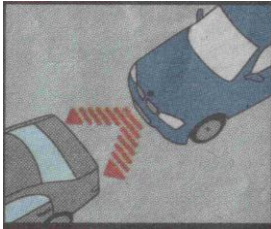

*'The system locks on to the car in front using an enhanced magnetic beam. Once you are attached, you are free to turn off your engine. The vehicle in front will do the pulling without noticing any changes.'*

Using physics principles, suggest how you can tell that the advertisement is an April Fool.

3

21. Some cars are fitted with a system that stores the energy normally lost as heat in the brakes. Estimate the maximum energy that could be stored as a car is decelerated to rest.

Clearly show your working for the calculation and any estimates you have made.

3

22. A book describing a medieval battle includes the following description of the flight of an arrow.

*'The arrow drew its curve in the sky, then fell fast, plunging, and losing its momentum.'*

Using physics principles, comment on the way the author has described the flight of the arrow.

3

23. 'They don't make them like they used to,' said old Uncle Willie as a breakdown truck towing a crashed car drove past. 'In my day, cars were built like tanks. They didn't crumple up in crashes like that one has', he continued.

Use your knowledge of physics to explain why certain parts of cars are designed to crumple in collisions.

3

24. An iron bar is heated. As the temperature of the bar increases, the colour of the bar changes from red to bluish white.

Use your knowledge of physics to explain this change in colour.

3

25. The star Betelgeuse has a surface temperature of about 2400 K and appears red when viewed.

The star Bellatrix has a surface temperature of about 25,000 K and appears bluish white.

Using your knowledge of physics explain the reason for the difference in colour of these stars.

3



