

Our Dynamic Universe

Homework Past paper problems

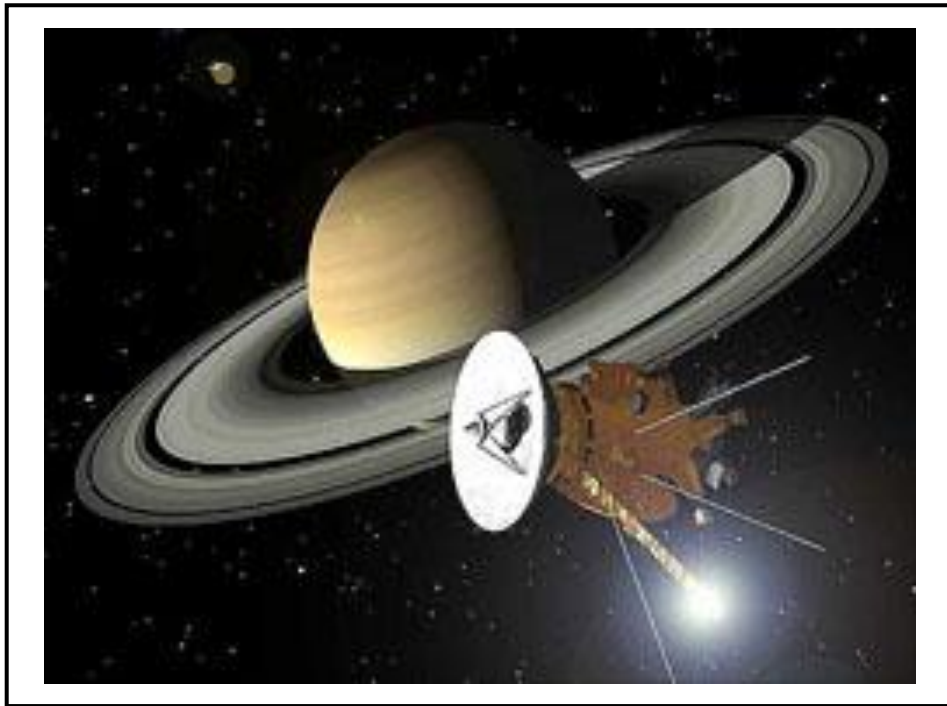

Exam Questions Part 1

Cover image: Artist's impression of Cassini spacecraft which has orbited Saturn since 2004, NASA

Contents

Section 0: Vectors	1
Section 1: Equations of motion	5
Section 2: Forces, energy and power	9
Section 3: Collisions and explosions	18

DATA SHEET
COMMON PHYSICAL QUANTITIES

Quantity	Symbol	Value	Quantity	Symbol	Value
Speed of light in vacuum	c	$3.00 \times 10^8 \text{ m s}^{-1}$	Planck's constant	h	$6.63 \times 10^{-34} \text{ J s}$
Magnitude of the charge on an electron	e	$1.60 \times 10^{-19} \text{ C}$	Mass of electron	m_e	$9.11 \times 10^{-31} \text{ kg}$
Universal Constant of Gravitation	G	$6.67 \times 10^{-11} \text{ m}^3 \text{ kg}^{-1} \text{ s}^{-2}$	Mass of neutron	m_n	$1.675 \times 10^{-27} \text{ kg}$
Gravitational acceleration on Earth	g	9.8 m s^{-2}	Mass of proton	m_p	$1.673 \times 10^{-27} \text{ kg}$
Hubble's constant	H_0	$2.3 \times 10^{-18} \text{ s}^{-1}$			

REFRACTIVE INDICES

The refractive indices refer to sodium light of wavelength 589 nm and to substances at a temperature of 273 K.

Substance	Refractive index	Substance	Refractive index
Diamond	2.42	Water	1.33
Crown glass	1.50	Air	1.00

SPECTRAL LINES

Element	Wavelength/nm	Colour	Element	Wavelength/nm	Colour
Hydrogen	656	Red	Cadmium	644	Red
	486	Blue-green		509	Green
	434	Blue-violet		480	Blue
	410	Violet	<i>Lasers</i>		
	397	Ultraviolet	<i>Element</i>	<i>Wavelength/nm</i>	<i>Colour</i>
	389	Ultraviolet	Carbon dioxide	9550 } 10590 }	Infrared
Sodium	589	Yellow	Helium-neon	633	Red

PROPERTIES OF SELECTED MATERIALS

Substance	Density/kg m ⁻³	Melting Point/K	Boiling Point/K
Aluminium	2.70×10^3	933	2623
Copper	8.96×10^3	1357	2853
Ice	9.20×10^2	273
Sea Water	1.02×10^3	264	377
Water	1.00×10^3	273	373
Air	1.29
Hydrogen	9.0×10^{-2}	14	20

The gas densities refer to a temperature of 273 K and a pressure of $1.01 \times 10^5 \text{ Pa}$.

Vectors

1. (a) State the difference between vector and scalar quantities. 1

(b) In an orienteering event, competitors navigate from the start to control points around a set course.

Two orienteers, Andy and Paul, take part in a race in a flat area. Andy can run faster than Paul, but Paul is a better navigator.



From the start, Andy runs 700 m north (000) then 700 m south-east (135) to arrive at the first control point. He has an average running speed of 3.0 m s^{-1} .

(i) By scale drawing or otherwise, find the displacement of Andy, from the starting point, when he reaches the first control point. 3

(ii) Calculate the average velocity of Andy between the start and the first control point. 2

(iii) Paul runs directly from the start to the first control point with an average running speed of 2.5 m s^{-1} .

Determine the average velocity of Paul. 1

(iv) Paul leaves the starting point 5 minutes after Andy.

Show by calculation who is first to arrive at the first control point. 3

(10)

2. Two ropes are used to pull a boat at constant speed along a canal.

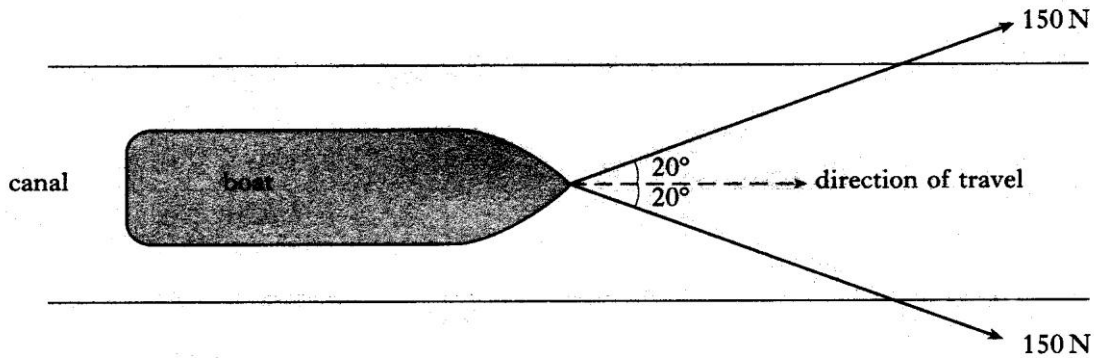

Each rope exerts a force of 150 N at 20° to the direction of travel of the boat as shown.

- (a) Calculate the magnitude of the resultant force exerted by the ropes. 2
- (b) What is the magnitude of the frictional force acting on the boat? 1
- (3)

3. A spectator at a football match stands at point A. He then walks to C, the opposite corner of a playing field, by walking from A to B and then from B to C as shown in the diagram below.

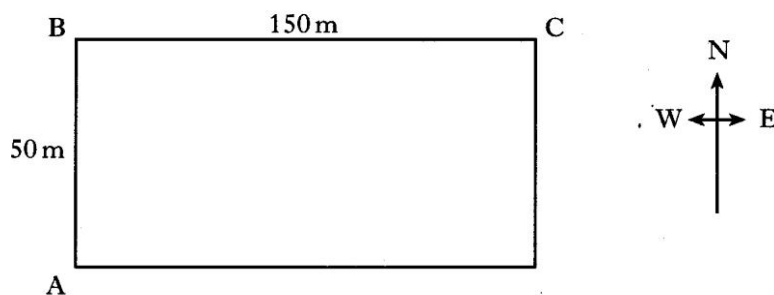

The distance from A to B is 50 m. The distance from B to C is 100 m.

- (a) By scale drawing or otherwise, find the resultant displacement. Magnitude and direction are required. 2
- (b) At the end of the football match the spectator walks directly from point C to point A.
- (i) Determine the total distance walked by the spectator. 1
- (ii) State the displacement of the spectator when he returns to point A. 1
- (4)

4. (a) State the difference between speed and velocity. 1

(b) During a tall ships race, a ship called the Mir passes a marker buoy X and sails due West (270). It sails on this course for 30 minutes at a speed of 10.0 km h^{-1} , then changes course to 20° West of North (340). The Mir continues on this new course for 1.5 hours at a speed of 8.0 km h^{-1} until it passes marker buoy Y.

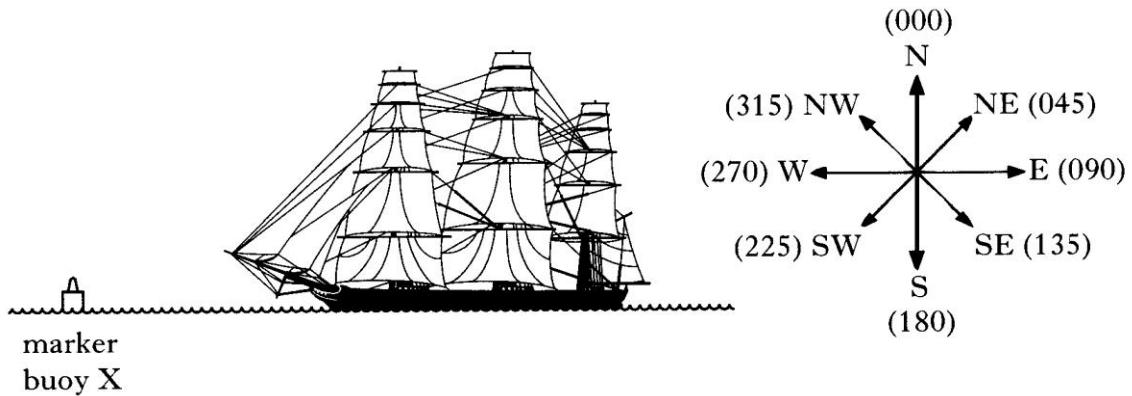

- (i) Show that the Mir travels a total distance of 17 km between marker buoys X and Y. 2
- (ii) By scale drawing or otherwise, find the displacement from marker buoy X to marker buoy Y. 2
- (iii) Calculate the average velocity, in km h^{-1} , of the Mir between marker buoy X and Y. 2
- (c) A second ship, the Leeuvin, passes marker buoy X fifteen minutes after the Mir and sails directly for marker buoy Y at a speed of 7.5 km h^{-1} . Show by calculation which ship first passes marker buoy Y. 2
- (9)

5. Competitors are racing remote control cars. The cars have to be driven over a precise route between checkpoints.

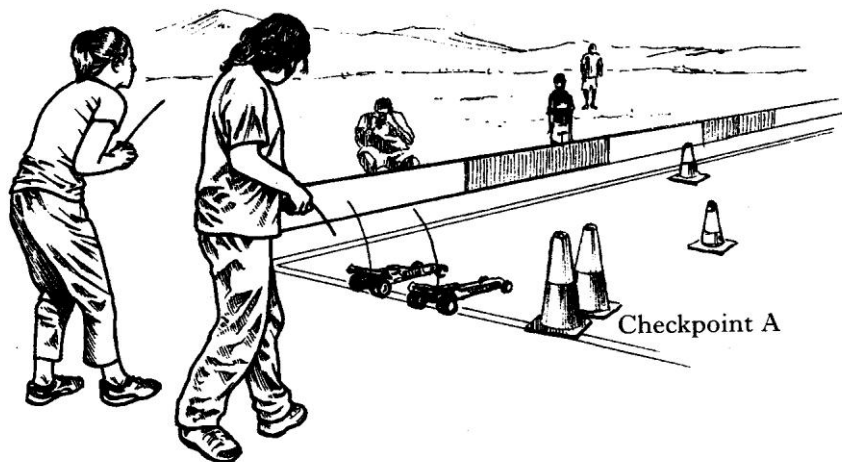

Each car is to travel from checkpoint A to checkpoint B by following these instructions.

“Drive 150 m due North, then drive 250 m on a bearing 60° East of North (060)”

Car X takes 1 minute 6 seconds to follow these instructions exactly.

- (a) By scale drawing or otherwise, find the displacement of checkpoint B from checkpoint A. 2
- (b) Calculate the average velocity of car X from checkpoint A to checkpoint B. 2
- (c) Car Y leaves A at the same time as X.
Car Y follows exactly the same route at an average speed of 6.5 m s^{-1} .
Which car arrives first at checkpoint B? Justify your answer with a calculation. 2
- (d) State the displacement of checkpoint A from checkpoint B. 1

(7)

Equations of Motion

1. In a “handicap” sprint race, sprinters P and Q both start at the same time but from different starting lines on the track. The handicapping is such that both sprinters reach line XY, as shown below, at the same.

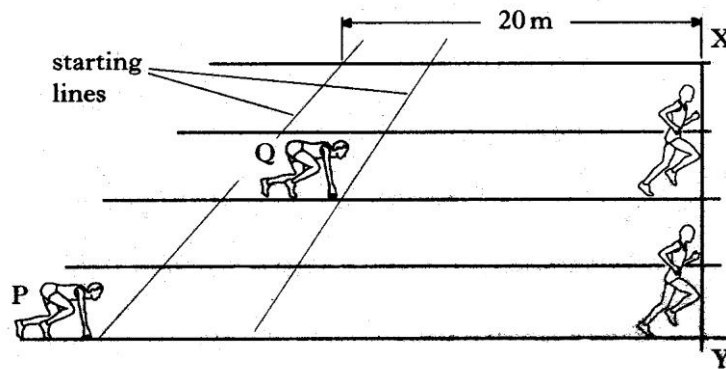

Sprinter P has a constant acceleration of 1.6 m s^{-2} from the start line to the line XY. Sprinter Q has a constant acceleration of 1.2 m s^{-2} from the start line to line XY.

- (a) Calculate the time taken by the sprinters to reach line XY. 2
- (b) Find the speed of **each** sprinter at this line. 3
- (c) What is the distance, in metres, between the starting lines for sprinters P and Q? 2
- (7)

2. (a) An object starts from rest and moves with constant acceleration a . After a time t , the velocity v and displacement s are given by

$$v = at \text{ and } s = \frac{1}{2}at^2 \text{ respectively.}$$

Use these relationships, to show that

$$v^2 = 2as. \quad 2$$

- (b) An aircraft of mass 1000 kg has a speed of 33 m s^{-1} before it takes off from a runway. The engine of the aircraft provides a constant thrust of 3150 N. A constant frictional force of 450 N acts on the aircraft as it moves along the runway.

(i) Calculate the acceleration of the aircraft along the runway. 2

(ii) The aircraft starts from rest. Calculate the minimum length of runway required for a take-off. 2

- (c) During a flight the aircraft is travelling with a velocity of 36 m s^{-1} due north (000).
A wind with a speed of 12 m s^{-1} starts to blow **towards** the direction of 40° west of north (320).

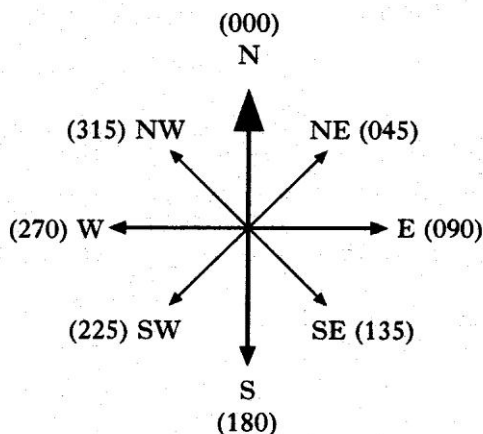

Find the magnitude and direction of the resultant velocity of the aircraft. 3

(9)

3. (a) A sports car is being tested along a straight track.

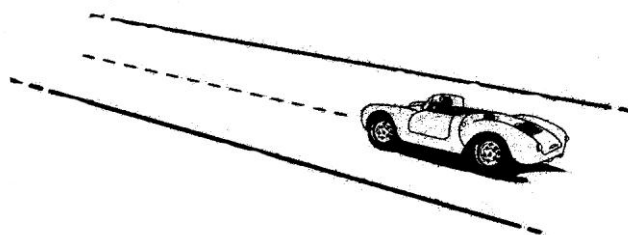

(i) In the first test, the car starts from rest and has a constant acceleration of 4.0 m s^{-2} in a straight line for 7.0 s .

Calculate the distance the car travels in the 7.0 s .

2

(ii) In a second test, the car again starts from rest and accelerates at 4.0 m s^{-2} over twice the distance covered in the first test.

What is the **increase** in the final speed of the car at the end of the second test compared with the final speed at the end of the first test?

2

(iii) In a third test, the car reaches a speed of 40 m s^{-1} . It then decelerates at 2.5 m s^{-2} until it comes to rest.

Calculate the distance travelled by the car while it decelerates to rest.

2

(b) A student measures the acceleration of a trolley as it moves freely down a sloping track.

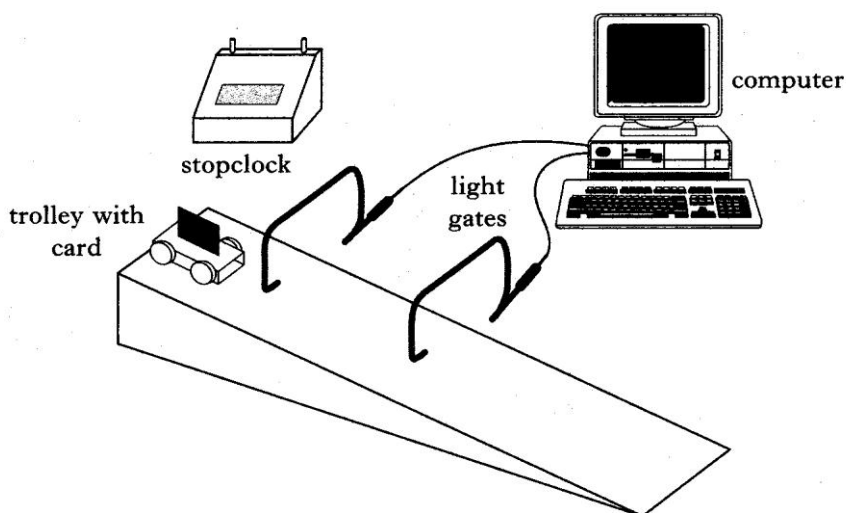

The trolley has a card mounted on it. As it moves down the track the card cuts off the light at each of the light gates in turn. Both the light gates are connected to a computer which is used for timing.

The student uses a stopclock to measure the time it takes the trolley to move from the first light gate to the second light gate.

- (i) List all the measurements that have to be made by the student and the computer to allow the acceleration of the trolley to be calculated. 2
 - (ii) Explain fully how each of these measurements is used in calculating the acceleration of the trolley as it moves down the slope. 2
- (10)

Force, Energy and Power

1. (a) A box of mass 18 kg is at rest on a horizontal frictionless surface. A force of 4.0 N is applied to the box at an angle of 26° to the horizontal.

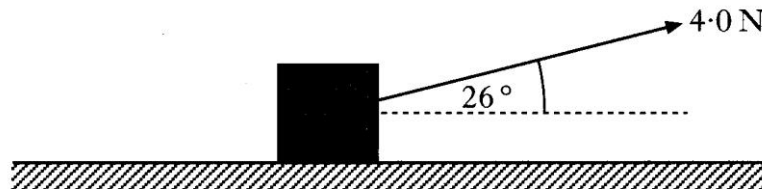

- (i) Show that the horizontal component of the force is 3.6 N. 1
- (ii) Calculate the acceleration of the box along the horizontal surface. 2
- (iii) Calculate the horizontal distance travelled by the box in a time of 7.0 s. 2
- (b) The box is replaced at rest at its starting position. The force of 4.0 N is now applied to the box at an angle of less than 26° to the horizontal.

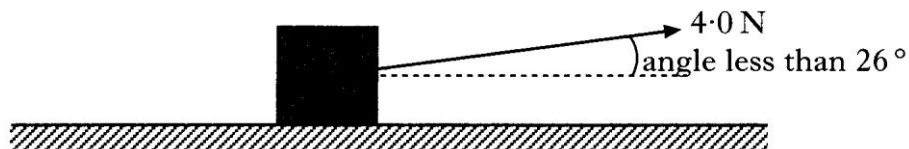

The force is applied for a time of 7.0 s as before. How does the distance travelled by the box compare with your answer to part (a)(iii)? You must justify your answer.

2

(7)

2. A “giant catapult” is part of a fairground ride.

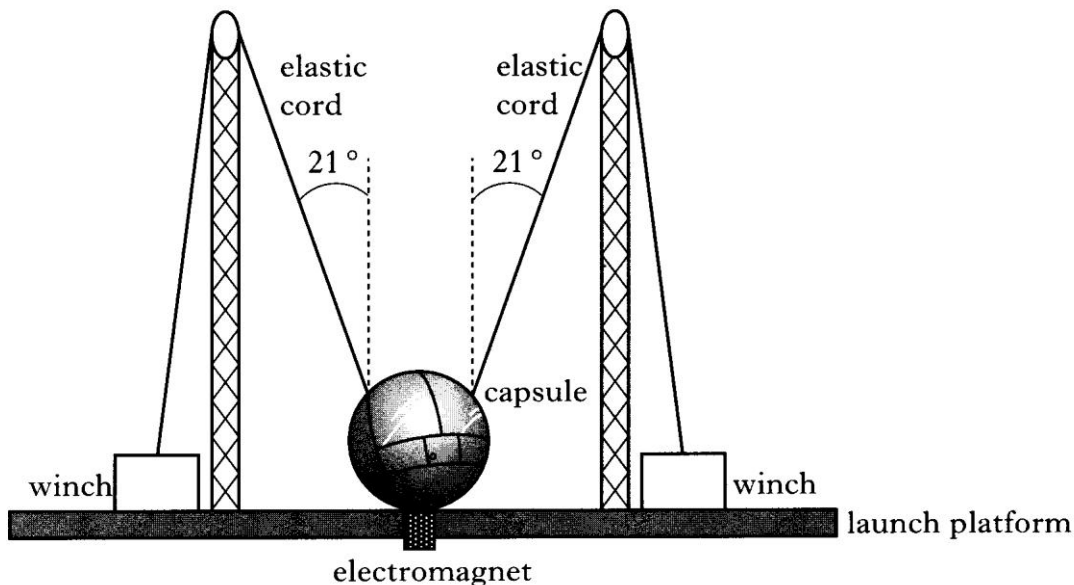

Two people are strapped into a capsule. The capsule and the occupants have a combined mass of 236 kg.

The capsule is held stationary by an electromagnet while the tension in the elastic cords is increased using the winches.

The mass of the elastic cords and the effects of air resistance can be ignored.

- (a) When the tension in each cord reaches 4.5×10^3 N the electromagnet is switched off and the capsule and occupants are propelled vertically upwards.
- (i) Calculate the vertical component of the force exerted by **each** cord just before the capsule is released. 1
 - (ii) Calculate the initial acceleration of the capsule. 3
 - (ii) Explain why the acceleration of the capsule decreases as it rises. 1
- (b) Throughout the ride the occupants remain upright in the capsule. A short time after release the occupants feel no force between themselves and the seats. Explain why this happens. 1

(6)

3. A van of mass 2600 kg moves down a slope which is inclined at 12° to the horizontal as shown.

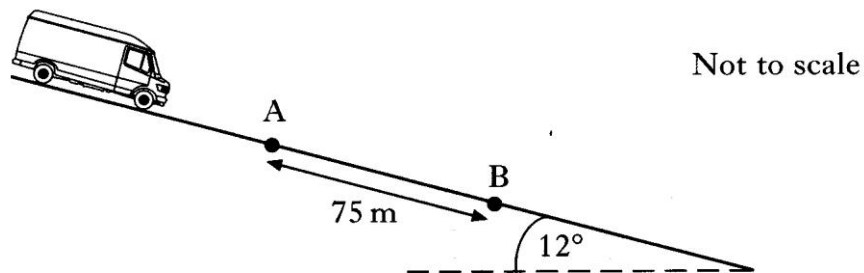

- (a) Calculate the component of the van's weight parallel to the slope. 2
- (b) A constant frictional force of 1400 N acts on the van as it moves down the slope.
Calculate the acceleration of the van. 2
- (c) The speed of the van as it passes point A is 5.0 m s^{-1} .
Point B is 75 m further down the slope.
Calculate the kinetic energy of the van at B. 3
- (7)

4. A fairground ride consists of rafts which slide down a slope into water.

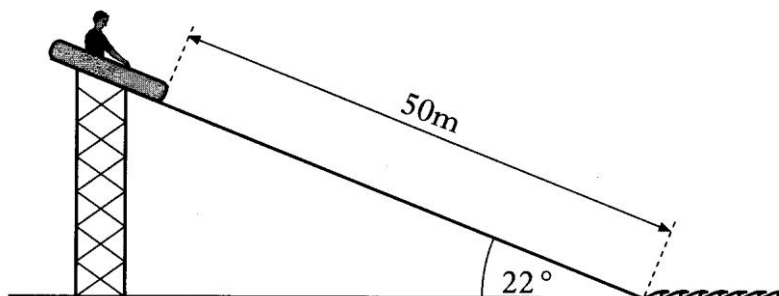

The slope is at an angle of 22° to the horizontal. Each raft has a mass of 8.0 kg . The length of the slope is 50 m .

A child of mass 52 kg sits in a raft at the top of the slope. The raft is released from rest. The child and raft slide together down the slope into the water. The force of friction between the raft and the slope remains constant at 180 N .

- (a) Calculate the component of weight, in newtons, of the child and raft down the slope. 1
 - (b) Show by calculation that the acceleration of the child and raft down the slope is 0.67 m s^{-2} . 2
 - (c) Calculate the speed of the child and raft at the bottom of the slope. 2
 - (d) A second child of smaller mass is released from rest in an identical raft at the same starting point. The force of friction is the same as before. How does the speed of the child and raft at the bottom of the slope compare with the answer to part (c)? Justify your answer. 2
- (7)

5. To test the braking system of cars, a test track is set up as shown.

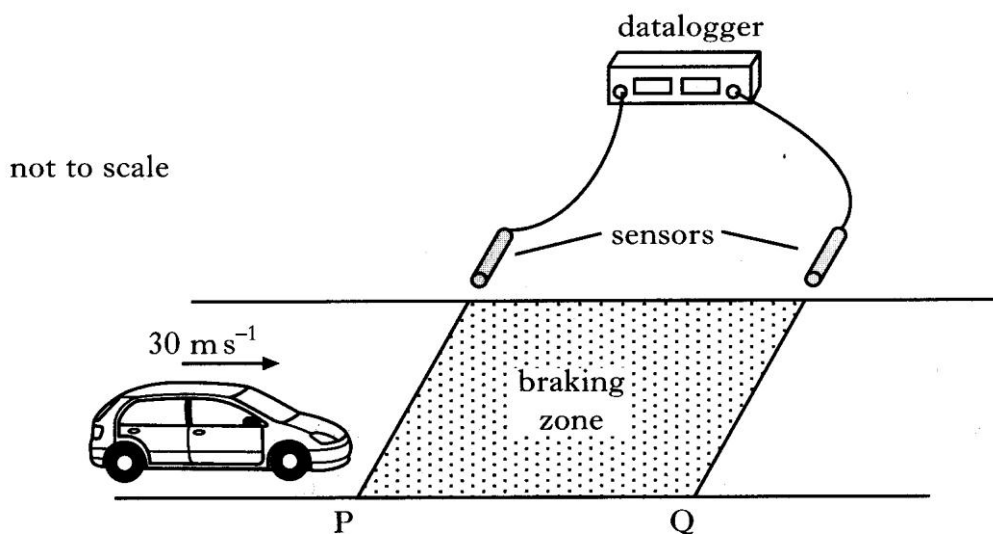

The sensors are connected to a datalogger which records the speed of the car at both P and Q.

A car is driven at a constant speed of 30 m s^{-1} until it reaches the start of the braking zone at P. The brakes are then applied.

- (a) In one test, the datalogger records the speed at P at 30 m s^{-1} and the speed at Q as 12 m s^{-1} . The car slows down at a constant rate of 9.0 m s^{-2} between P and Q.

Calculate the length of the braking zone.

2

- (b) The test is repeated. The same car is used but now with passengers in the car. The speed at P is again recorded as 30 m s^{-1} . The same braking force is applied to the car as in part (a). How does the speed of the car at Q compare with its speed at Q in part (a)? Justify your answer.

2

(4)

6. A crate of mass 40.0 kg is pulled up a slope using a rope. The slope is at an angle of 30° to the horizontal.

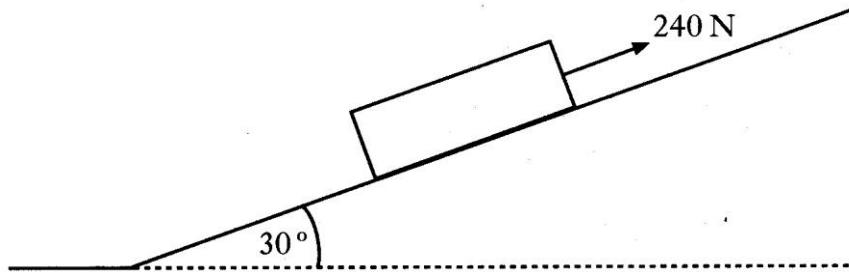

A force of 240 N is applied to the crate parallel to the slope. The crate moves at a constant speed of 3.0 m s^{-1} .

- (a) (i) Calculate the component of the weight acting parallel to the slope, 2
(ii) Calculate the frictional force acting on the crate. 2
- (b) As the crate is moving up the slope, the rope snaps. The graph shows how the velocity of the crate changes from the moment the rope snaps.

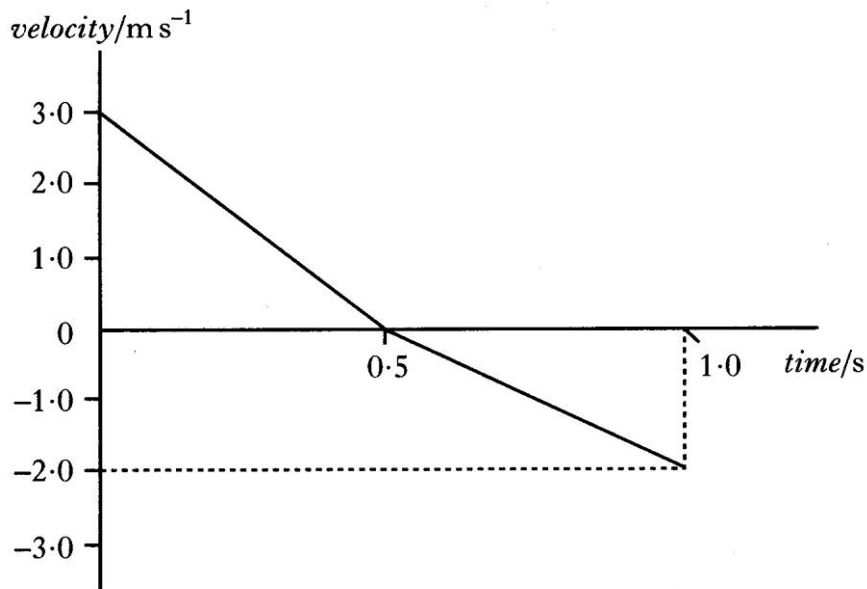

- (i) Describe the motion of the crate during the first 0.5 s after the rope snaps. 1

- (ii) Copy the axes shown below and sketch the graph to show the acceleration of the crate between 0 and 1.0 s. Appropriate numerical values are also required on the acceleration axis. 2

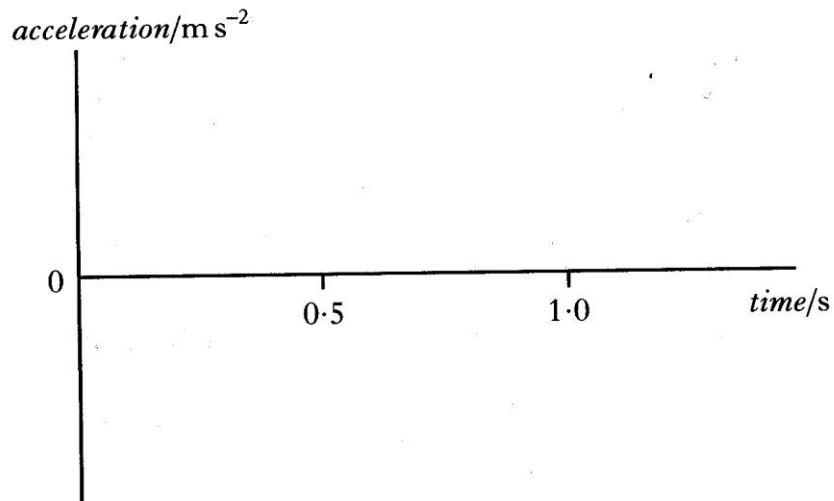

- (iii) Explain, in terms of the forces acting on the crate, why the magnitude of the acceleration changes at 0.5 s. 2
- (9)

7. A helicopter is flying at a constant height above ground. The helicopter is carrying a crate suspended from a cable as shown.



- (a) The helicopter flies 20 km on a bearing of 180 (due South). It then turns on to a bearing of 140 (50° South of East) and travels a further 30 km.

The helicopter takes 15 minutes to travel the 50 km.

- (i) By scale drawing or otherwise, find the resultant displacement of the helicopter. 2
- (ii) Calculate the average velocity of the helicopter during the 15 minutes. 2
- (b) The helicopter reaches its destination and hovers above a drop zone.
- (i) The total mass of the helicopter and crate is 1.21×10^4 kg. Show that the helicopter produces a lift force of 119 kN. 1
- (ii) The helicopter now drops the crate which has a mass of 2.30×10^3 kg. Describe the vertical motion of the helicopter immediately after the crate is dropped. Justify your answer in terms of the forces acting on the helicopter. 2

(7)

8. A bungee jumper is attached to a high bridge by a thick elastic cord.

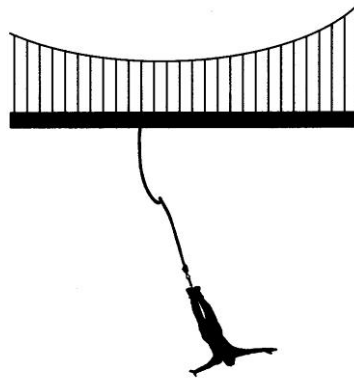

The graph shows how the velocity of the bungee jumper varies with time during the first 6 s of a jump.

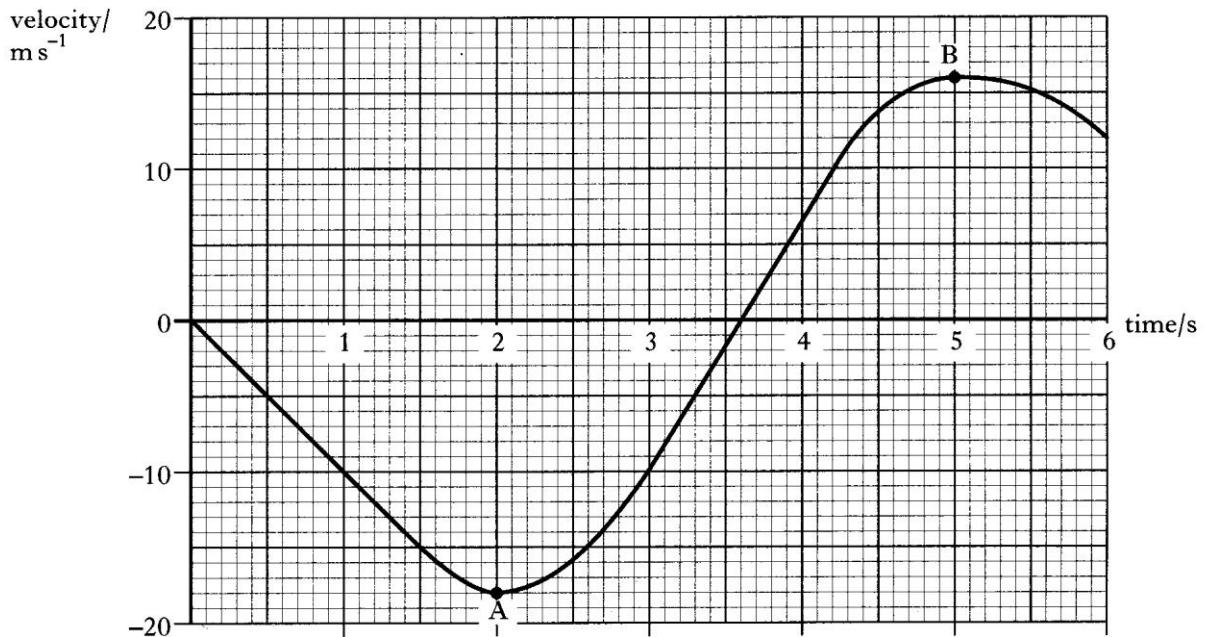

The mass of the bungee jumper is 55 kg.

- Using the information on the graph, state the time at which the bungee rope is at its maximum length. 2
 - Calculate the average unbalanced force, in newtons, acting on the bungee jumper between points A and B on the graph. 2
 - Explain, in terms of the force of the rope on the bungee jumper, why an elastic rope is used rather than a rope which cannot stretch very much. 2
- (6)

Collisions and Explosions

1. The apparatus shown below is used to test concrete pipes.

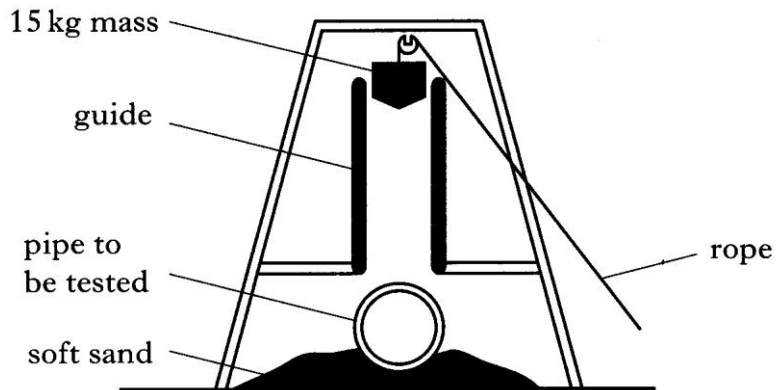

When the rope is released, the 15 kg mass is dropped and falls freely through a distance of 2.0 m on to the pipe.

- (a) In one test, the mass is dropped on to an uncovered pipe.
- (i) Calculate the speed of the mass just before it hits the pipe. 3
- (ii) When the 15 kg mass hits the pipe the mass is brought to rest in a time of 0.020 s. Calculate the size and direction of the average unbalanced force on the **pipe**. 2
- (b) The same 15 kg mass is now dropped through the same distance on to an identical pipe which is covered with a thick layer of soft material. Describe and explain the effect this layer has on the size of the average unbalanced force on the pipe.
- (c) Two 15 kg, X and Y, shaped as shown, are dropped through the same distance on to identical uncovered concrete pipes.



When the masses hit the pipes, the masses are brought to rest in the same time.

Using your knowledge of physics, explain which mass causes more damage to a pipe. 2

(9)

2. Two ice skaters are initially skating together, each with a velocity of 2.2 m s^{-1} to the right as shown.

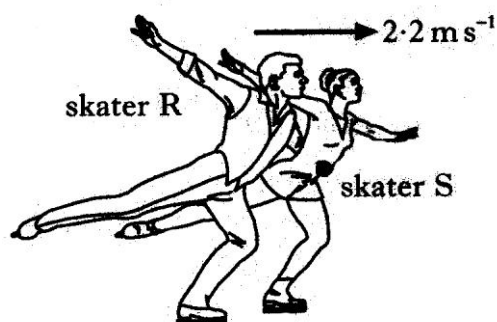

The mass of skater R is 54 kg . The mass of skater S is 38 kg .

Skater R now pushes skater S with an average force of 130 N for a short time. This force is in the same direction as their original velocity.

As a result, the velocity of skater S increases to 4.6 m s^{-1} to the right.

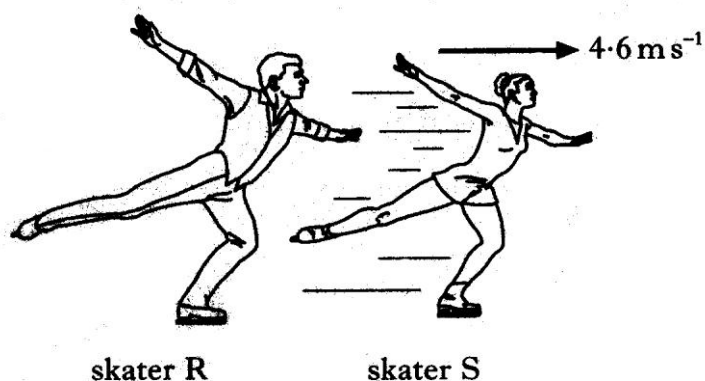

- (a) Calculate the magnitude of the change in momentum of skater S. 2
- (b) Calculate how long skater R exerts the force on skater S. 2
- (c) Calculate the velocity of skater R immediately after pushing skater S. 2
- (d) Is this interaction between the skaters elastic? You must justify your answer by calculation. 3

(9)

3. (a) A space vehicle of mass 2500 kg is moving with a constant speed of 0.50 m s^{-1} in the direction shown. It is about to dock with a space probe of mass 1500 kg which is moving with a constant speed in the opposite direction.

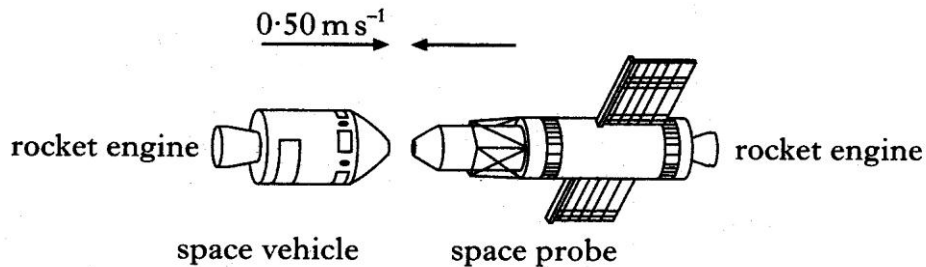

After docking, the space vehicle and the space probe move off together at 0.20 m s^{-1} in the original direction in which the space vehicle was moving.

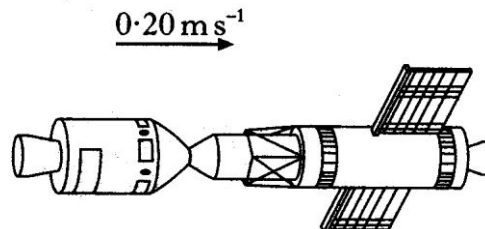

Calculate the speed of the space probe before it docked with the space vehicle.

2

- (b) The space vehicle has a rocket engine which produces a constant thrust of 1000 N. The space probe has a rocket engine which produces a constant thrust of 500 N.

The space vehicle and space probe are now brought to rest from their combined speed of 0.20 m s^{-1} .

- (i) Which rocket engine was switched on to bring the vehicle and probe to rest?
- (ii) Calculate the time for which this rocket engine was switched on. You may assume that a negligible mass of fuel was used during this time.

1

2

- (c) The space vehicle and space probe are to be moved from their stationary position at A and brought to rest at position B, as shown.

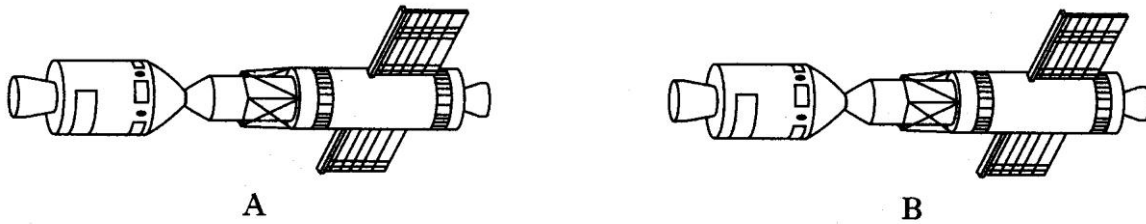

Explain clearly how the rocket engines of the space vehicle and the space probe are used to complete this manoeuvre.

Your explanation must include an indication of the relative time for which each rocket engine must be fired.

You may assume that a negligible mass of fuel is used during this manoeuvre.

2

(7)

4. A force sensor is used to investigate the impact of a ball as it bounces on a flat horizontal surface. The ball has a mass of 0.050 kg and is dropped, vertically from rest, through a height of 1.6 m as shown.

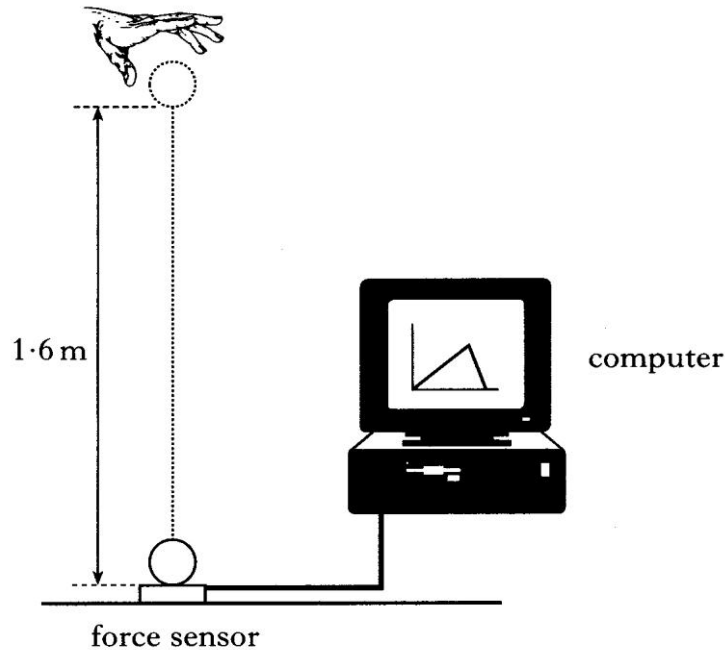

- (a) The graph shows how the force on the ball varies with time during the impact.

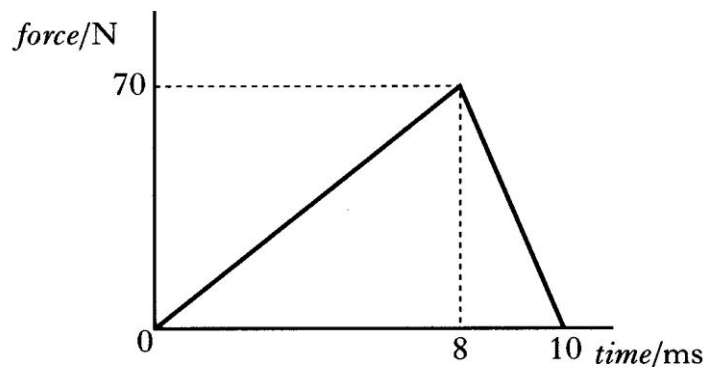

- (i) Show by calculation that the magnitude of the impulse on the ball is 0.35 Ns. 1
- (ii) What is the magnitude and direction of the change in momentum of the ball? 1
- (iii) The ball is travelling at 5.6 m s^{-1} just before it hits the force sensor. Calculate the speed of the ball just as it leaves the force sensor. 2

- (b) Another ball of identical size and mass, but made of harder material, is dropped from rest and from the same height on to the same force sensor. Sketch the force-time graph shown above and, on the same axes, sketch another graph to show how the force on the harder ball varies with time. Numerical values are not required but you must label the graphs clearly.

2

(6)

5. An experiment is set up to investigate the motion of a cart as it collides with a force sensor.

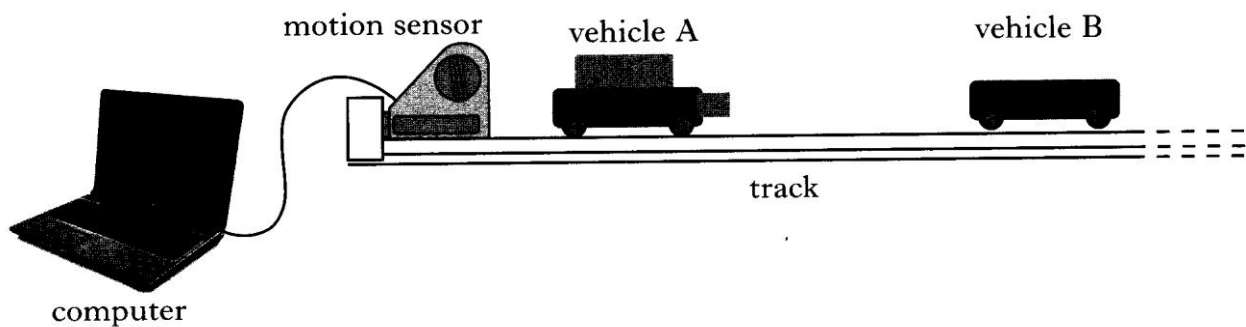

The cart moves along the horizontal track at 0.48 m s^{-1} to the right.

As the cart approaches the force sensor, the magnets repel each other and exert a force on the cart.

The computer attached to the force sensor displays the following force-time graph for the collision.

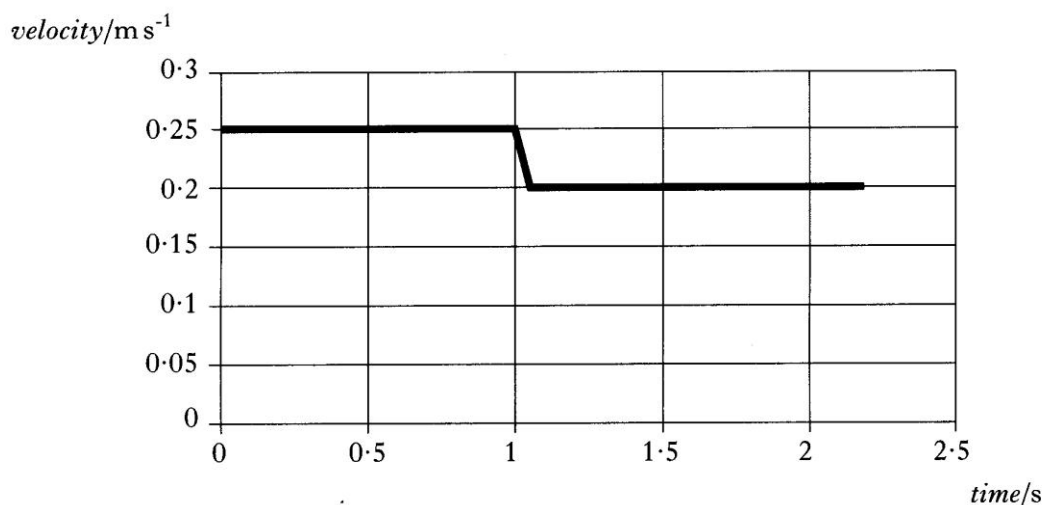

The computer attached to the motion sensor displays the following velocity-time graph for the cart.

- (a) (i) Calculate the magnitude of the impulse on the cart during the collision. 2
- (ii) Determine the magnitude and direction of the change in momentum of the cart. 1
- (iii) Calculate the mass of the cart. 2

- (b) The experiment is repeated using different magnets which produce a greater average force on the cart during the collision. As before, the cart is initially travelling at 0.48 m s^{-1} to the right and the collision causes the same change in its velocity.

Copy the force-time graph shown and, on the same axes, draw another graph to show how the magnitude of the force varies with time in this collision.

Numerical values are not required but you must label each graph clearly.

2

(7)

6. (a) State the law of conservation of linear momentum.

1

(b) The diagram shows a linear air track on which two vehicles are free to move. Vehicle A moves towards vehicle B which is initially at rest.

A computer displays the speeds of the two vehicles before and after the collision.

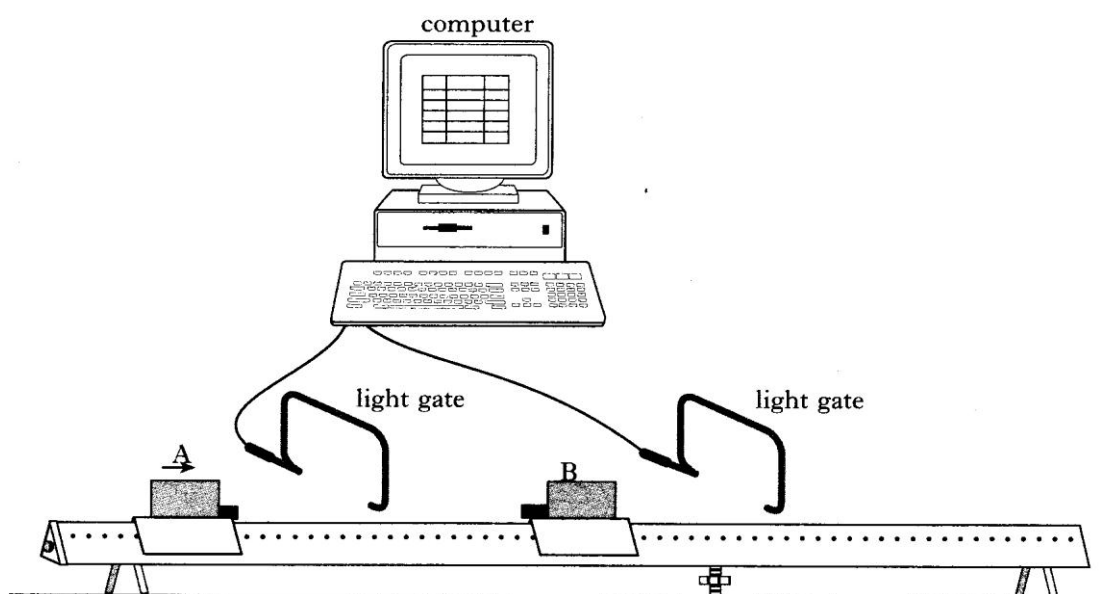

The table of results below shows the mass and velocity of each vehicle before and after the collision.

<i>Vehicle</i>	<i>Mass</i>	<i>Velocity before collision</i>	<i>Velocity after collision</i>
A	0.75 kg	0.82 m s ⁻¹ to the right	0.40 m s ⁻¹ to the right
B	0.50 kg	0.00 m s ⁻¹	0.63 m s ⁻¹ to the right

(i) Use these results to show that the change in momentum of vehicle A is equal in size but opposite in direction to the change in momentum of vehicle B.

2

(ii) Use the data in the table to show whether the collision is elastic or inelastic.

3

(6)

7. (a) A bullet of mass 25 g is fired horizontally into a sand-filled box which is suspended by long strings from the ceiling. The combined mass of the bullet, box and sand is 10 kg.

After impact, the box swings upwards to reach a maximum height as show in the diagram.

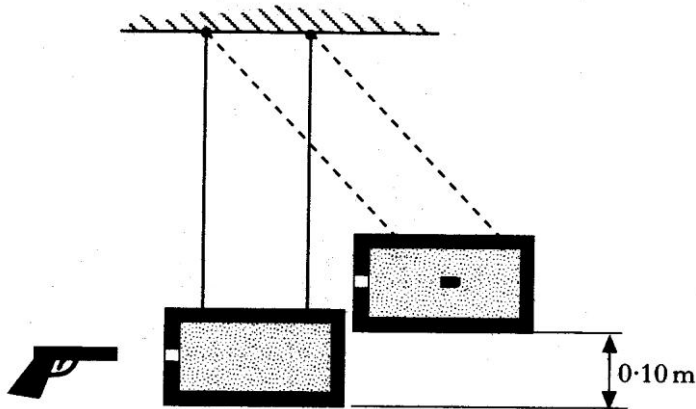

Calculate:

- (i) the maximum velocity of the box after impact; 2
- (ii) the velocity of the bullet just before impact. 2
- (b) The experiment is repeated with a metal plate fixed to one end of the box as shown.

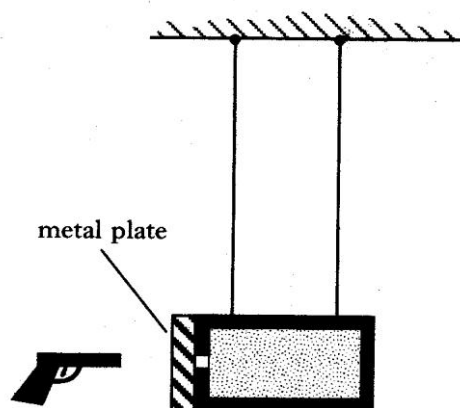

The mass of sand is reduced so that the combined mass of the sand, box and metal plate is 10 kg.

In this experiment, the bullet bounces back from the metal plate. Explain how this would affect the maximum height reached by the box compared with the maximum height reached in part (a). 2

(6)

8. During a test on car safety, two cars are crashed together on a test track as shown below.



- (a) Car A, which has a mass of 1200 kg and is moving at 18.0 m s^{-1} , approaches car B, which has a mass of 1000 kg and is moving at 10.8 m s^{-1} , in the opposite direction.

The cars collide head on, lock together and move off in the direction of car A.

- (i) Calculate the speed of the cars immediately after the collision. 2
- (ii) Show by calculation that the collision is inelastic. 2
- (b) During a second safety test, a dummy in a car is used to demonstrate the effects of a collision.

During the collision, the head of the dummy strikes the dashboard at 20 m s^{-1} as shown and comes to rest in 0.020 s .

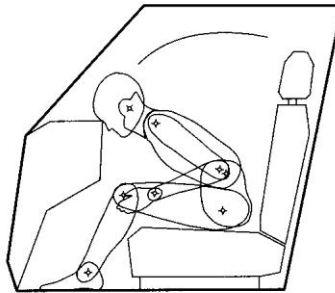

The mass of the head is 5.0 kg .

- (i) Calculate the average force exerted by the dashboard on the head of the dummy during the collision. 2

- (ii) The test on the dummy is repeated with an airbag which inflates during the collision. During the collision, the head of the dummy again travels forward at 20 m s^{-1} and is brought to rest by the airbag.

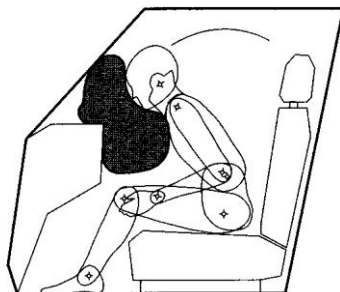

Explain why there is less risk of damage to the head of the dummy when the airbag is used.

2

(8)